

PORTABLE TYPE ULTRASONIC FLOWMETER (PORTAFLOW-C)

DATA SHEET

FSC, FLD/FSD

PORTAFLOW-C is a portable type ultrasonic flowmeter utilizing the transit time measuring method, using a clamp-on type detector.

It is a compact and lightweight instrument incorporating the latest electronics and digital signal processing technologies, realizing high performance and easy operation.

FEATURES

1. **Compact and lightweight**
The adoption of the latest electronics and digital signal processing technologies has reduced the size and weight of the flow transmitter by 30% and 30%, respectively, in comparison with the Fuji conventional portable flowmeter (Model FSC).
2. **Battery operation**
The flowmeter is designed for 12 hours of continuous operation via built-in battery which is rechargeable in 3 hours with the exclusive power adapter.
3. **Full variety of detectors**
The flowmeter is suitable for various types of detectors applicable for small to large diameter pipe ($\phi 13$ to $\phi 6000\text{mm}$) and low to high temperature (-40 to $+200^\circ\text{C}$).
4. **High accuracy and high-speed response**
The flowmeter is designed for high accuracy ($\pm 1.0\%$). Response time is within 1 second.
5. **Improved anti-bubble characteristic**
Anti-bubble characteristic is greatly improved by digital signal processing.
6. **Excellent performance and easy operation**
Large graphic LCD that is outside but easy to read. Minimum number of function keys are used for page selection, allowing easy setting.
The flowmeter is water resistant and tolerates exposure to rain.
7. **Large capacity storage by SD memory card**
Measured data is periodically stored in SD memory card. For example, in case of 256MB, it can be saved about 1 year measurement date (In case of saving period 30 seconds, 14 kinds of saved data). Available up to 8MB (Option 256MB)
8. **Serial communication**
Use of a USB port allows easy connection to a personal computer. Measured data collection panel and Loader software for PC (standard) which is available for display and change of parameter (site setting) are prepared.
9. **Heat quantity (calorie) measurement**
Heat quantity (calorie) may be measured by temperature input, making energy management easy for cooling and heating.
10. **Graphic printer connection (option)**
Easy recording with the Integral type printer.



Flow transmitter (FSC)

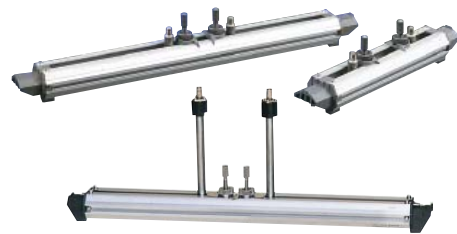

Detector (FLD)

11. **Flow velocity profile measurement (option)**
Flow profile may be observed in real time.

SPECIFICATIONS

Measuring objects

Measurement fluid:

Uniform liquid in which ultrasonic waves can propagate.

Turbidity of fluid: 10000 mg/L or less

State of fluid: Well-developed turbulent or laminar flow in a filled pipe.

Fluid temperature: -40 to $+200^\circ\text{C}$

Measuring range: $0 \dots \pm 0.3$ to $\pm 32\text{m/s}$

Piping conditions

Applicable piping material:

Select from carbon steel, stainless steel, cast iron, PVC, FRP, copper, aluminum, acrylic or material of known sound velocity.

Pipe size:

Flow rate measurement
 $\phi 13$ to $\phi 6000\text{mm}$
Flow velocity profile measurement
 $\phi 40$ to $\phi 1000\text{mm}$

Lining material: Select from no lining, tar epoxy, mortar, rubber, Teflon, pyrex glass or material of known sound velocity.
Note) No gap allowed between the lining and the pipe.

Straight pipe length:

10D or more upstream and 5D or more downstream (D: internal pipe diameter)
Refer to Japan Electric Measuring Instruments Manufacturers' Association's standard JEMIS-032 for details.

Performance specifications

Accuracy rating:

Piping diameter (inner diameter)	Flow velocity range	Accuracy
φ13 to φ25mm	2 to 32m/s	±2.5% of rate
	0 to 2m/s	±0.05m/s
φ25 to φ50mm	2 to 32m/s	±1.5% of rate
	0 to 2m/s	±0.03m/s
φ50 to φ300mm	2 to 32m/s	±1.0% of rate
	0 to 2m/s	±0.02m/s
φ300 to φ6000mm	1 to 32m/s	±1.0% of rate
	0 to 1m/s	±0.01m/s

Note) Reference conditions are based on JEMIS-032.

Flow transmitter (Type: FSC)

Power supply: Built-in battery or AC power adapter
Built-in battery: Exclusive lithium button battery (5000m Ah)
Continuous operation time, approx. 12 hours (without printer, back light OFF, output current not used and at normal ambient temperature (20°C))
Recharging time, approx. 3 hours (power adapter used)
Recharging temperature range: 0 to +40°C
Power consumption: Min. 3W and Max. 16W
The consumption varies depending on the use conditions.

Power adapter: Exclusive power adapter 90V to 264V AC (50/60Hz)

LCD: Semi-transmissive color graphic display 240 × 320 (with back light)
Measurement value (instantaneous flow rate, integrated flow rate) and various settings are displayed.
Excellent visibility even outdoors in direct sunlight.

LED display: Status display when using AC power adapter.
DC IN (green): Power supply status
CHARGE (red): Battery charging underway

Operation keypad:
11 buttons
(ON, OFF, ENT, ESC, MENU, △, ▽, ◀, ▶, LIGHT, PRINT)

Power failure backup:
Measurement value is backed up by nonvolatile memory.
Clock backup with lithium battery (effective term, 10 years or more)

Response time: 1 second

Analog output signals:
4 to 20mA DC, one point (load resistance, 600Ω or less)
Instantaneous velocity, instantaneous flow rate or heat quantity (calorie) after scaling.

Analog input signal:

4 to 20mA DC, one point (input resistance, 200Ω or less)
4 to 20mA DC, one point (input resistance, 200Ω or less)
or 1 to 5V DC, one point
Used to input temperature for heat quantity measurement, etc.

Total 2 points

SD memory card: Used for data logger function and recording screen data.
Available up to 8GB (Option256MB)
Compliant media
• SD memory card: speed class 2, 4, 6
• SDHC memory card: speed class 4, 6
Format
• FAT12: 64MB
• FAT16: 128MB to 2GB
• FAT32: 4GB, 8GB
Otherwise, reading and saving are impossible.
File format
• Date logger: CSV file
• Screen date: Bit map file

Serial communication:
USB port (device* compatible):
Mini B receptacle
Connectable number of Mini B receptacles:
1 unit
Transmission distance: 3m max.
Transmission speed: 500kbps
Data:
Instantaneous velocity, instantaneous flow rate, total value, heat quantity (calorie) value, error information, logger data, etc.
* Device: Connected plug from PC

Printer (option): To be mounted on top of transmitter unit
Thermal line dot printing
When the Chinese display is selected, printing is made in kanji characters.

Ambient temperature:
-10 to +55°C (Without printer)
-10 to +45°C (With printer)

Ambient humidity: 90%RH or less
Type of enclosure: IP64 (Without printer)
Enclosure case: Plastic case
Outer dimensions: H210 × W120 × D65mm (Without printer)
H320 × W120 × D65mm (With printer)
Weight: 1.0kg (Without printer)
1.2kg (With printer)

Various functions

Display language: Selectable from Japanese, English, German, French, Spanish or Chinese (switchable by key operation).

Clock display function:
Time (year, month, day, hour, minute) display (configurable)
Monthly error: about 1 minutes at normal temperature (20°C).
However, time error at power ON/OFF is not included.

Instantaneous value display function:

Instantaneous velocity, instantaneous flow rate display (The flow in reverse direction is displayed with minus "-.")
 Numeric value: 10 digits (decimal point equals 1 digit)
 Unit: Metric/English system selectable
 Metric system
 Velocity: m/s
 Flow rate: L/s, L/min, L/h, L/d, kL/d, ML/d, m³/s, m³/min, m³/h, m³/d, km³/d, Mm³/d, BBL/s, BBL/min, BBL/h, BBL/d, kBBL/d, MBBL/d
 English system
 Velocity: ft/s
 Flow rate: gal/s, gal/min, gal/h, gal/d, kgal/d, Mgal/d, ft³/s, ft³/min, ft³/h, ft³/d, kft³/d, Mft³/d, BBL/s, BBL/min, BBL/h, BBL/d, kBBL/d, MBBL/d

Total value display function:

Display of forward or reverse total (reverse is displayed as minus)
 Numeric value: 10 digits (decimal point is corresponding to 1 digit)
 Unit: Metric/English system selectable
 Metric system
 Flow rate total: mL, L, m³, km³, Mm³, mBBL, BBL, kBBL
 English system
 Flow rate total: gal, kgal, ft³, kft³, Mft³, mBBL, BBL, kBBL, ACRE-ft

Consumed heat quantity (calorie) display function:

Display of consumed heating medium
 Metric system
 Heat flow: MJ/h, GJ/h
 Total heat quantity: MJ, GJ
 English system
 Heat flow: MJ/h, GJ/h, BTU/h, kBTU/h, MBTU/h
 Total heat quantity: MJ, GJ, BTU, kBTU, MBTU

Computation function of consumed heat quantity (calorie):

This function calculates the heat quantity received and sent with liquid (water) in cooling and heating.

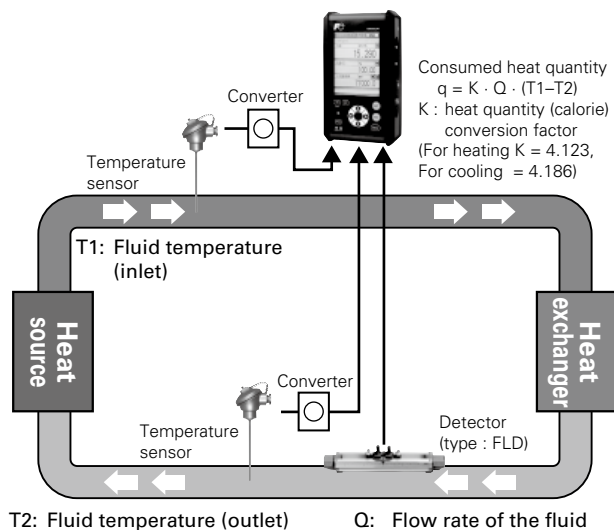

Temperature display function:

Fluid temperature be displayed by current input from temperature transmitter.
 Metric system
 Temperature unit: °C or K
 English system
 Temperature unit: F or K

Site data storage function:

Max. 32 locations (sites) data (pipe size, material, fluid type and etc) can be stored into built-in non-volatile memory.

Damping:

0 to 100sec (every 0.1sec) configurable for analog output and velocity/flow rate display

Low flow cut: Equivalent to 0 to 5m/s

Output setting function:

Current output scaling, output type, burnout setting and calibration

Serial communication function:

Instantaneous velocity, instantaneous flow rate, total value, heat flow, error information, received waveform, analog input, velocity profile data, logger data, etc. may be downloaded to personal computer.

Logger function:

Instantaneous velocity, instantaneous flow rate, total value, heat flow, error information, received waveform, analog input, velocity profile data can be saved in a SD memory card.

Waveform display function:

Bi-directional received waveforms may be displayed.

Graph display function:

Flow rate trend graph may be displayed.

Printing function (option):

Hard copy output of a screen
 Periodic printing (type: text, graph)
 Logger date (type: text, graph)

Flow velocity profile measurement (option):

Flow velocity profile may be observed in real time using the exclusive detector (option).
 (Refer to page 5 for details.)

Detector (Type: FLD)

Type of detector:

Kind	Type	Internal pipe diameter (mm)	Fluid temperature
Small type	FLD12	φ50 to φ400	-40 to 100°C
Small diameter	FLD22	φ13 to φ100	-40 to 100°C
High temperature	FLD32	φ50 to φ400	-40 to 200°C
Middle type	FLD41	φ200 to φ1200	-40 to 80°C
Large type	FLD51	φ200 to φ6000	-40 to 80°C

Mounting method:

Mounting on outside of existing pipe

Sensor mounting method: V or Z method

Signal cable: Exclusive coaxial cable
 Standard 5m

Method for connection:

Flow transmitter side
 Exclusive connector
 Detector side
 Large/middle type: Screw terminal
 Others: BNC connector

FLOW VELOCITY PROFILE DISPLAY FUNCTION (OPTION)

Flow velocity profile can be observed in real time using the dedicated detector from the outside. It is specifiable by the code symbol of flow transmitter.

APPLICATION

Pulse Doppler method is applicable to observe flow velocity profile in real time, display the flow status in the pipe, and decide the appropriate measurement location. Also, it can be used for diagnosis of flow and laboratory test.

SPECIFICATIONS

Measuring fluid: Uniform liquid in which ultrasonic waves can propagate.

Turbidity of fluid: Axisymmetric flow in a filled pipe.

Fluid temperature:

–40 to +100°C (FSDP2)

–40 to +80°C (FSDP1, FSDP0)

Air bubble quantity:

0.02 to 15Vol% (Velocity is 1m/s)

Pipe size: Small type sensor : $\phi 40$ to $\phi 200$ mm

Middle type sensor : $\phi 100$ to $\phi 400$ mm

Large type sensor : $\phi 200$ to $\phi 1000$ mm

Measurement range:

0 to ± 0.3 : \pm Maximum Velocity (depending on the pipe diameter)

Refer to chart, page 6.

Note) This function is to observe flow velocity profile, and it may be different from actual flow rate.

DETECTOR FOR FLOW VELOCITY PROFILE MEASUREMENT (TYPE: FSD)

Mounting method:

Mounting on outside of existing pipe

Ambient temperature: –20 to +80°C

Ambient humidity: 100% RH or less

Type of enclosure:

IP67 (with waterproof BNC connector provided.)

Material:

Sensor housing: PBT

Guide frame: Aluminum alloy

Mounting belt: Plastic cloth belt/stainless belt

Measurement principle

<Pulse Doppler method>

- Ultrasonic pulses are transmitted through the fluid flow. Entrained bubbles and microscopic particles within the fluid create frequency phase shifts (Doppler effect.) The resulting doppler shifts are integrated across the inside pipe diameter cross section. The resulting profile curve is a real-time dynamic display of the flow profile within the pipe.

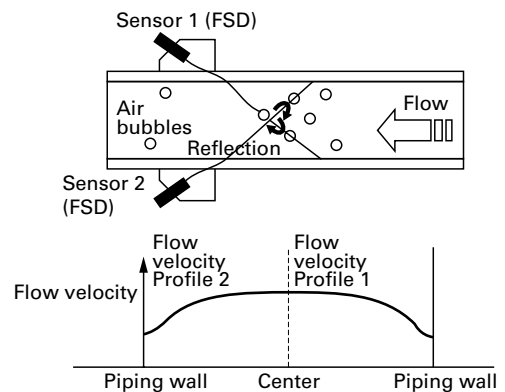

The above shows an example when using two sensors. One detector displays the flow velocity profile for a radius.

Block diagram

(1) Using one sensor

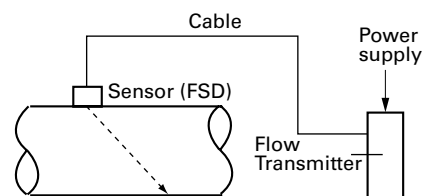

(2) Using two sensors

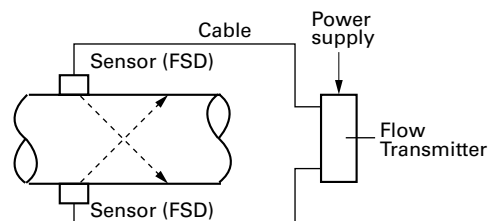

<Maximum measurable flow velocity>

Unit: m/s

Diameter	FSDP2	FSDP1	FSDP0
40A	6.56		
50A	6.52		
65A	5.31		
80A	4.65		
90A	4.12		
100A	3.69	7.25	
125A	3.08	6.08	
150A	2.63	5.20	
200A	2.04	4.05	7.77
250A		3.30	6.38
300A		2.78	5.41
350A		2.51	4.90
400A		2.20	4.31
450A			3.80
500A			3.48
550A			3.17
600A			2.91
650A			2.71
700A			2.52
750A			2.35
800A			2.21
850A			2.08
900A			1.97
1000A			1.77

<Maximum measurable flow rate>

Unit: m³/h

FSDP2	FSDP1	FSDP0
33.6		
52.7		
72.1		
86.5		
102		
118	231	
147	289	
179	354	
239	474	908
	604	1168
	735	1428
	820	1598
	951	1858
		2118
		2358
		2618
		2879
		3096
		3357
		3618
		3879
		4140
		4400
		4902

PC Loader software

Equipped as standard

- PC/AT compatible machines.
- Operation on custom built PCs or shop-brand PCs cannot be guaranteed.
- Major functions: Performs parameter (site setting) display /change of the main unit and collects measured date.

Instantaneous velocity, instantaneous flow rate, total value, error information, received waveform, analog input, logger data, etc. may be downloaded in a personal computer.

- O/S: Windows2000/XP/Vista*
- Memory requirement: 128MB or more
- Disk unit: Windows2000/XP/Vista-compatible CD-ROM drive
- Hard disk drive capacity: Free space of 52MB or more

* Windows Vista: Use it in basic mode.
It is not available for Windows Aero.

CODE SYMBOL

<Flow transmitter>

1 2 3 4 5 6 7 8 9 10										Description
F	S	C						1	0	<Specification> Standard
								S		<Converter> Basic system Basic system + Printer
								1		<Flow velocity profile measurement> None Provided (detector to measure flow velocity profile is separately required.)
								2		
								0		<Power adapter> AC power + power cord (125V AC) for Japanese and North American use AC power + power cord (250V AC) for European and Korean use AC power + power cord (250V AC) for Chinese use
								1		
								A		
								B		Modification No.
								C		
								1		<SD memory card> None Provided (256MB)
								0		
								1		

Diagram

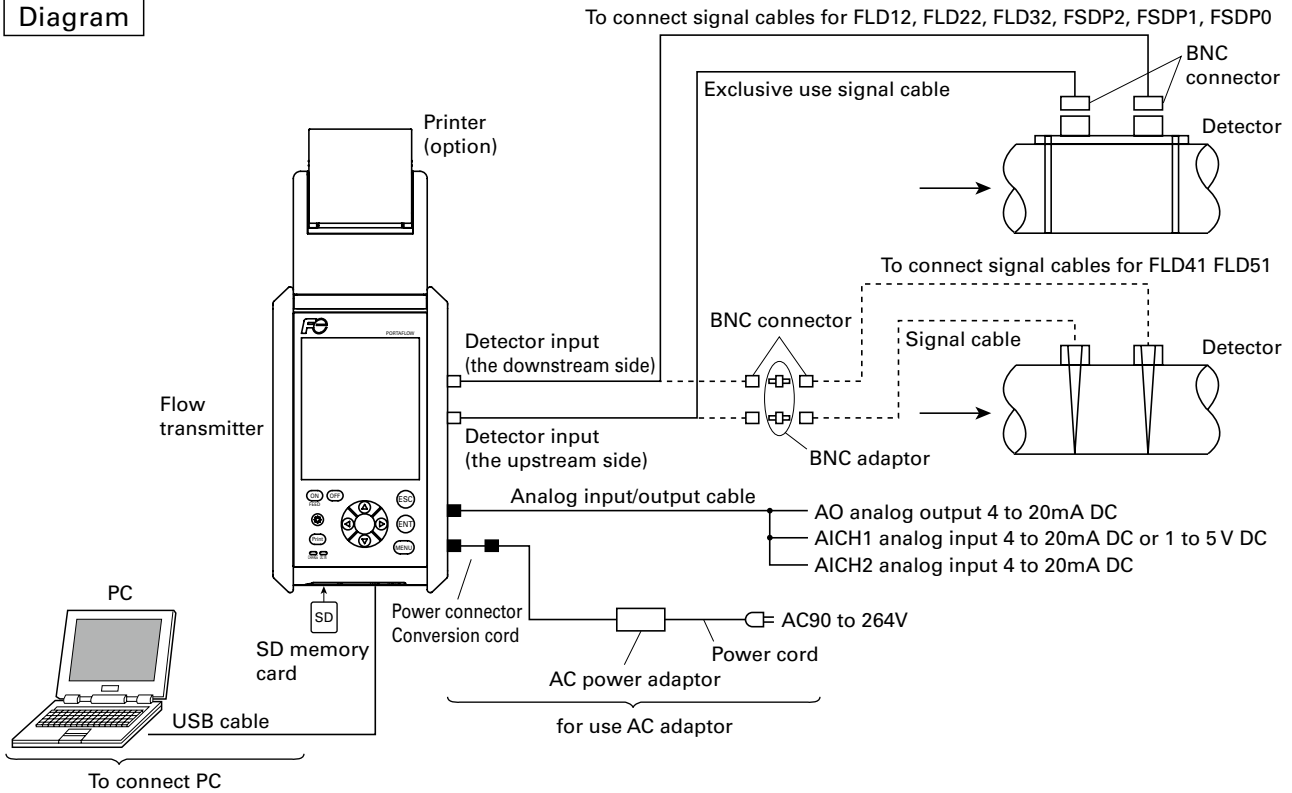

Conditions on straight pipe

(D: Nominal diameter of pipe)

Type	Length of upstream straight pipe	Length of downstream straight pipe
90° bend		
Tee		
Diffuser		
Contraction pipe		
Valve		
Pump		

Note) Source: Japan Electric Measuring Instruments Manufacturers' Association (JEMIS-032)

OUTLINE DIAGRAM (Unit:mm)

Flow transmitter

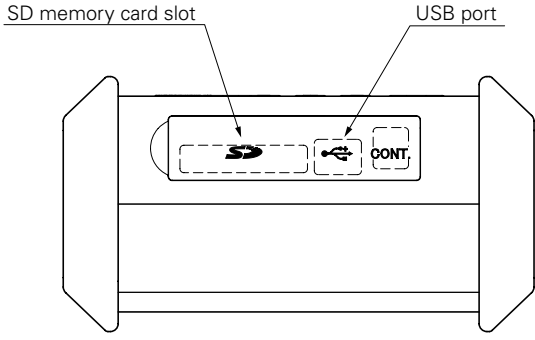
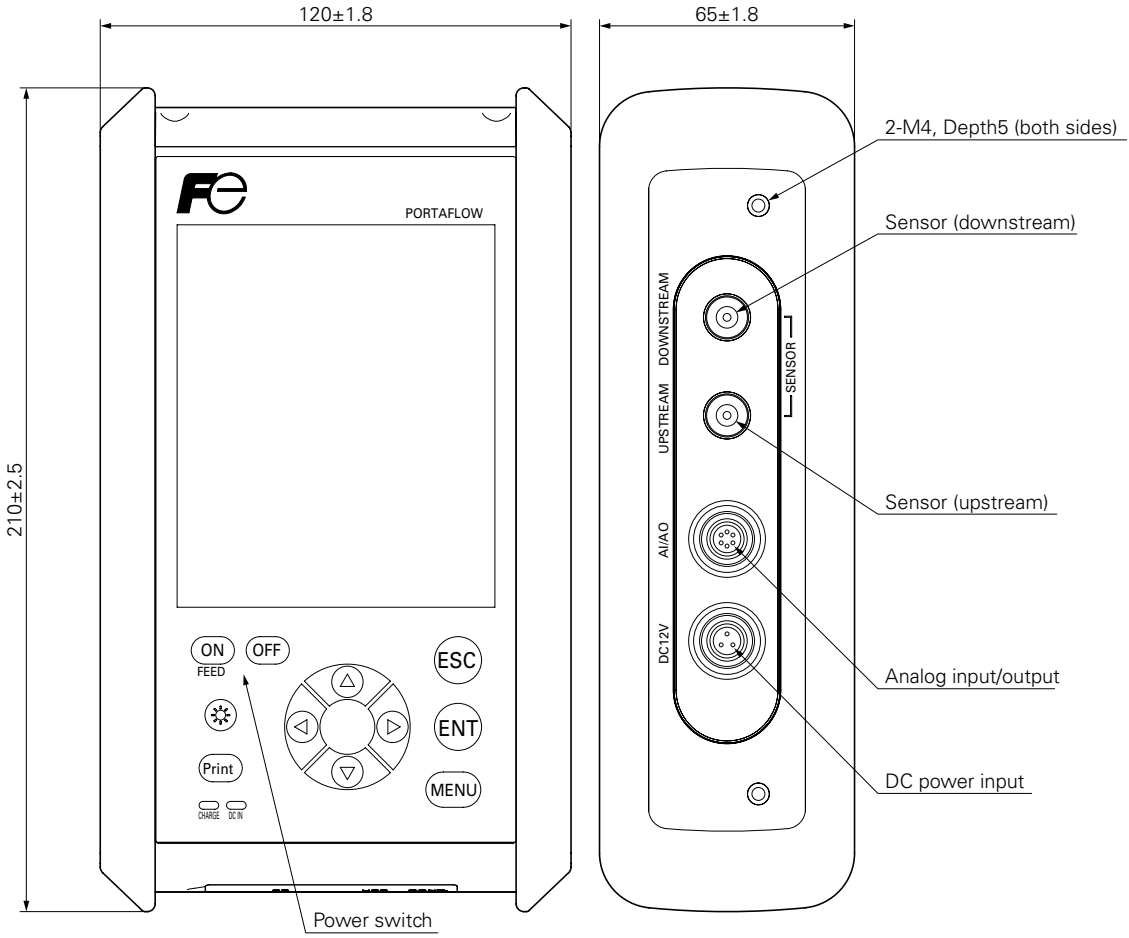

Weight : Approx. 1.0kg

OUTLINE DIAGRAM (Unit:mm)

Flow transmitter (with printer)

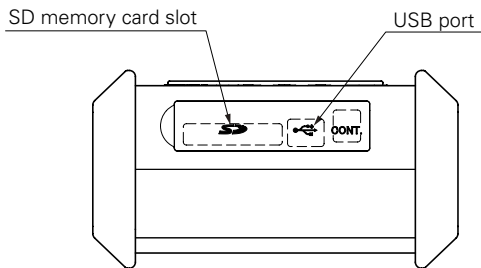
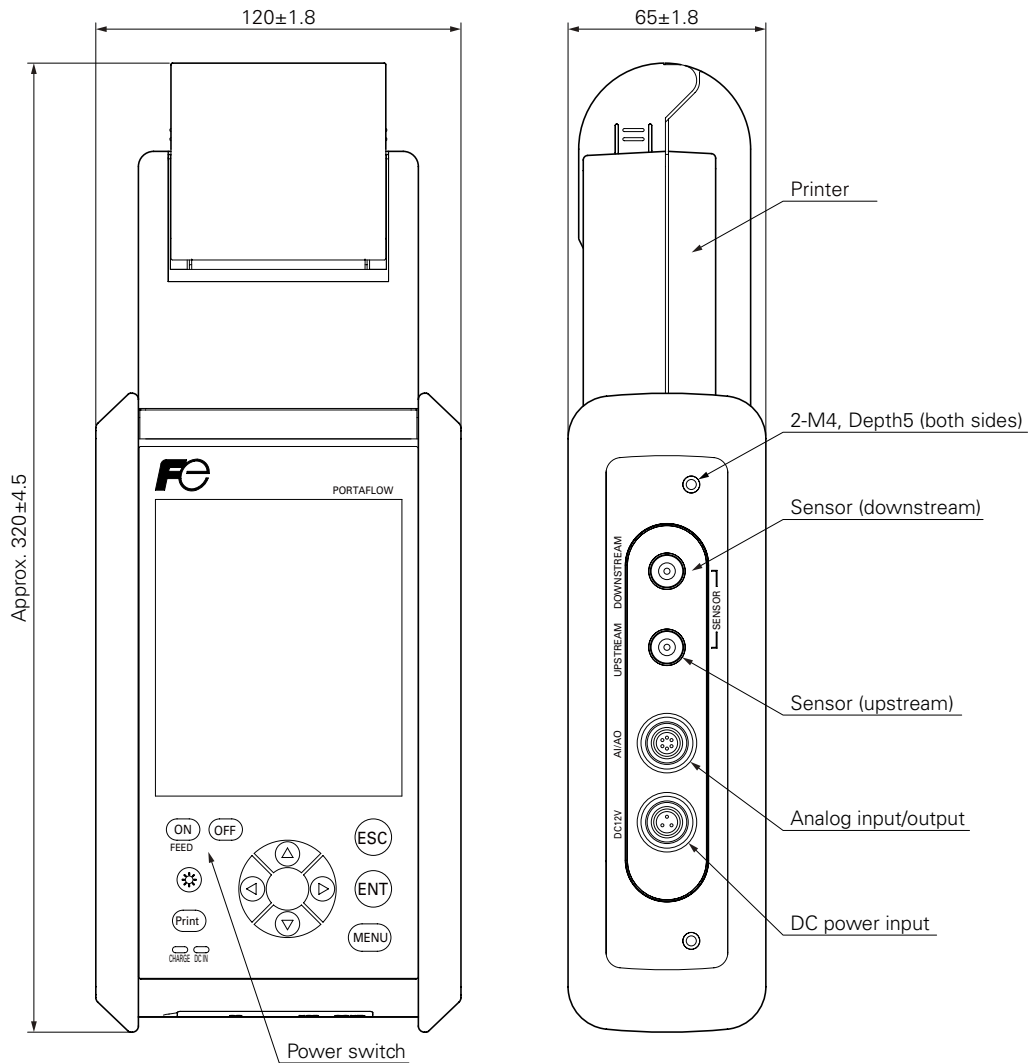

Weight : Approx. 1.2kg

OUTLINE DIAGRAM (Unit:mm)

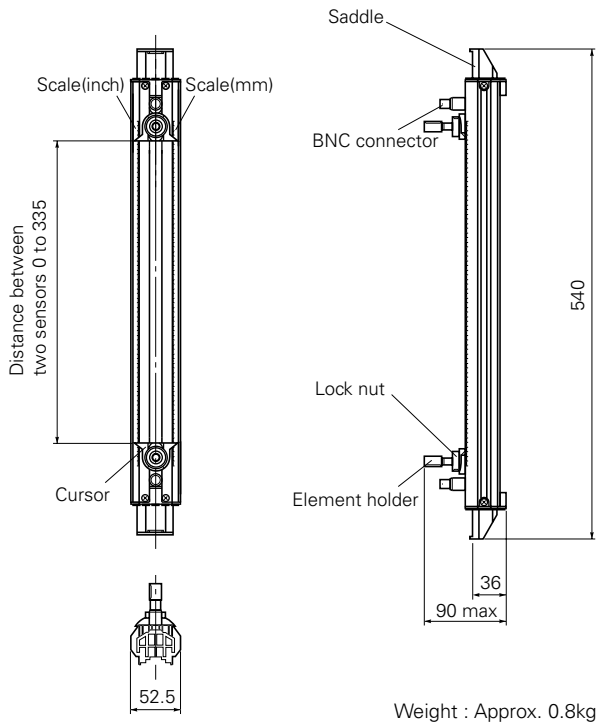

Detector FLD12 (Small type)

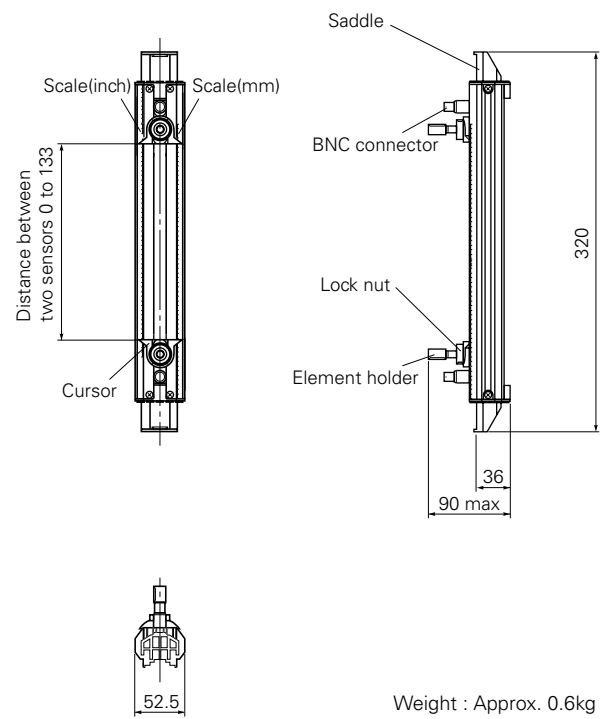

Detector FLD22 (Small diameter)

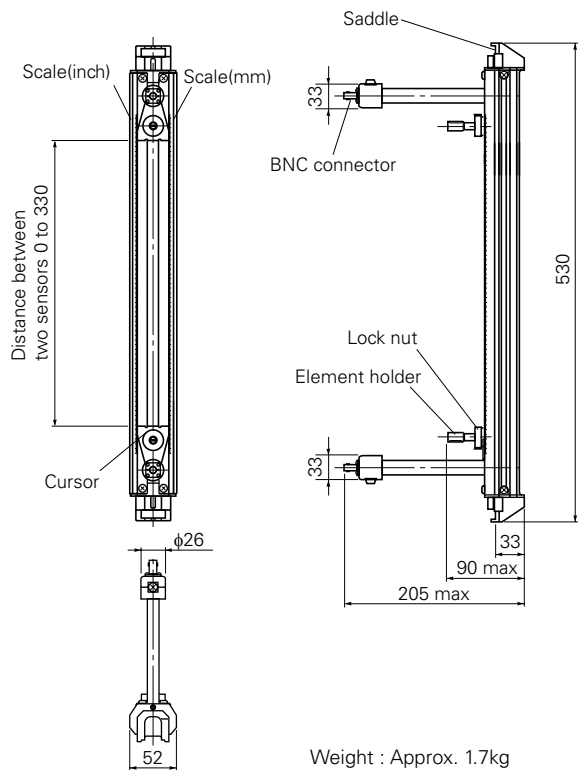

Detector FLD32 (High-temperature)

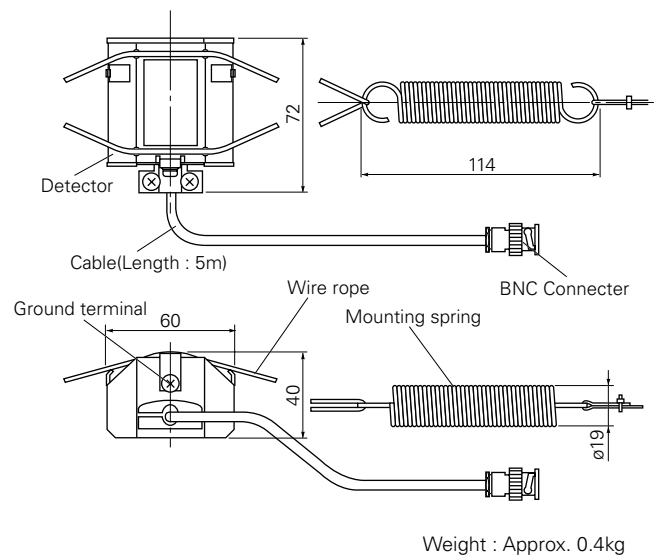

Detector FLD41 (Middle type)

OUTLINE DIAGRAM (Unit:mm)

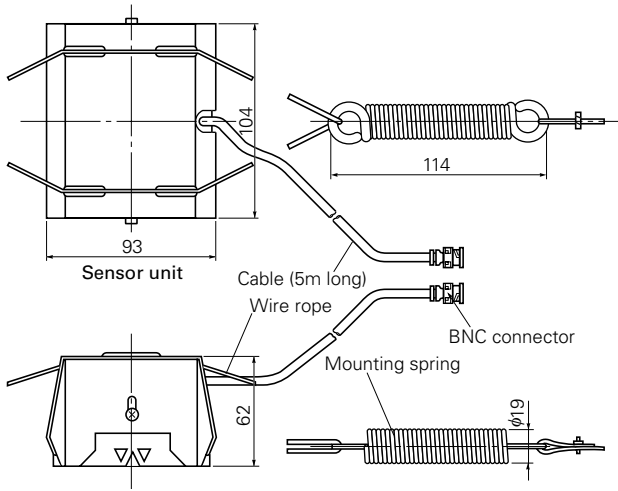

Weight : Approx. 1.4kg

Detector FLD51 (Large type)

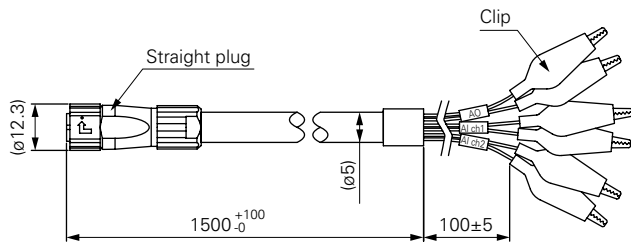
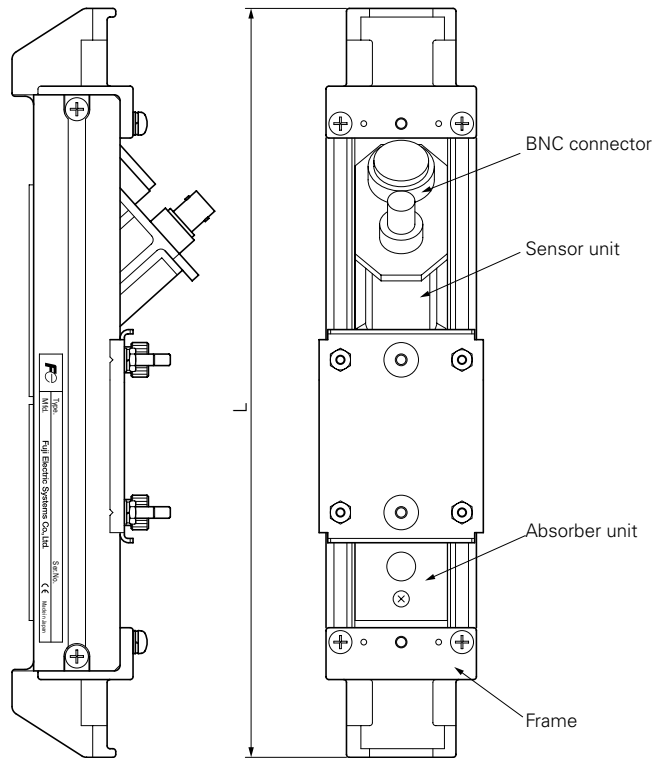

Weight : approx. 0.1kg

Code color	Clip color	Mark
Black (BK)	Red (R) (+)	AO
White (W)	Black (BK) (-)	
Red (R)	Red (R) (+)	AI ch1
Green (G)	Black (BK) (-)	AI ch2
Yellow (Y)	Red (R) (+)	
Brown (BN)	Black (BK) (-)	

Analog input/output cable

Type	Diameter (mm)	L	H	W	Weight Approx. (kg)
FSDP2	φ40 to φ200	260±1.2	70	57	0.8
FSDP1	φ100 to φ400	260±1.2	72	57	0.9
FSDP0	φ200 to φ1000	350±2.0	90	85	2.0

Detector FSD (Detector for flow velocity profile measurement)

⚠ Caution on Safety

*Before using this product, be sure to read its instruction manual in advance.

Fuji Electric Systems Co., Ltd.

**Sales Div. III, International Sales Group
Global Business Group**

Gate City Ohsaki, East Tower, 11-2, Osaki 1-chome,
Shinagawa-ku, Tokyo 141-0032, Japan

<http://www.fesys.co.jp/eng>

Phone: 81-3-5435-7280, 7281 Fax: 81-3-5435-7425

<http://www.fic-net.jp/eng>