

# FUJI MARKER LOCATOR

---

# MLH-1

---

## OPERATION MANUAL

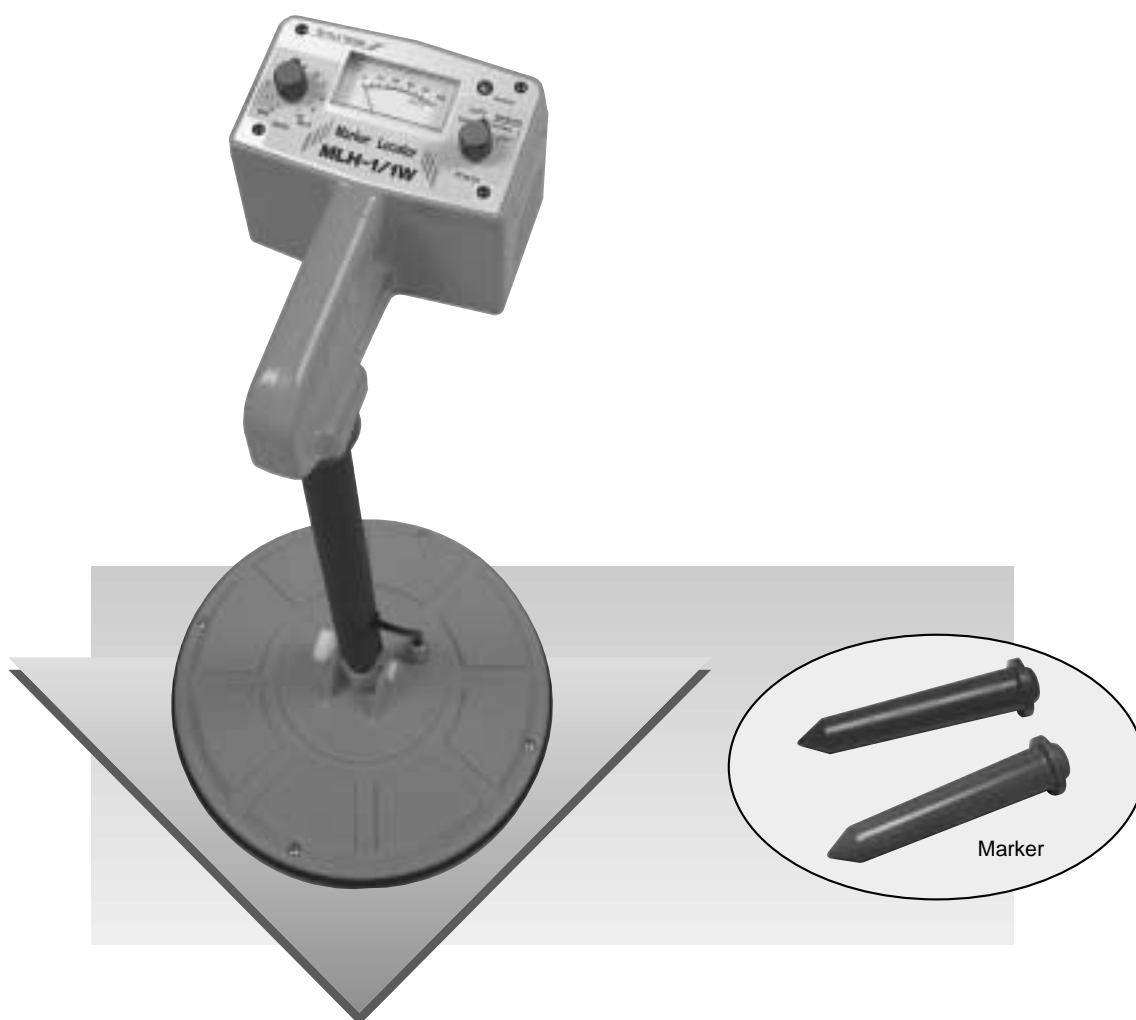

## INDEX

---

PERFACE .....	2
WARRANTY .....	2
⚠ WARNING .....	3
1. COMPONENTS .....	4
2. SYSTEM DESCRIPTION .....	5
3. EXAMINATION BEFORE USE .....	6
3 – 1 BATTERY INSPECTION	
3 – 2 BATTERY REPLACEMENT	
3 – 3 OPERATING INSPECTION	
4. USAGE .....	7
4 – 1 HOW TO OPERATE MLH-1 LOCATOR	
4 – 2 HOW TO OBTAIN THE POINT RIGHT UPON MARKER	
5. HOW TO LAY MARKER .....	8
6. CAUTIONS FOR MARKER .....	9
7. APPLICATION EXAMPLES .....	13
8. SPECIFICATIONS .....	14

## **PREFACE**

Thank you very much for your selection of Fuji MLH-1 Marker Locator.

In order to have MLH-1 Locator utilized to satisfy your locating work on site, you are required to read this Instruction Manual not only to know how to operate this locator but also to prevent a trouble of instrument and an accident on site.

## **WARRANTY**

Fuji warranty period is one year (12 months) from the date of your purchase of MLH-1 Marker Locator from either a Fuji distributor or FUJI TECOM INC..

Warranty Card attached to each MLH-1 Locator is indispensable for maintenance service. You are required to keep it carefully.

When your MLH-1 Locator is malfunctioned in your ordinary use or handling, you can have it repaired at free of charge within the warranty period. Thus, please send the malfunctioned MLH-1 Locator to a Fuji distributor or FUJI TECOM INC. within the warranty period. When sending it back, you are suggested to mention the defective condition clearly in writing preferably.

Please note that after the warranty period, either our distributor or we take the liberty to require the charge incurred for repair of your MLH-1 Locator.



## **WARNING**

- Do not utilize this instrument except proper purpose.
- Pay your special attention to the surrounding circumstances especially to the traffic accident when operating the MLH-1 Marker Locator on site. The protection and prevention against accident is required to be carried out under your own responsibility.
- Do not operate MLH-1 Locator in the rain due to the fact that it is not of the waterproof structure. The rain will soak into amplifier housing of the locator and cause a malfunction.
- Avoid strong physical shock or vibration. MLH-1 Locator is not of the shockproof.
- Do not attach any seals or plates to the part of the antenna of the locator. This might cause deterioration of the sensitivity.
- Do not keep MLH-1 Locator at a place where is high temperature.

## 1. COMPONENTS

Your MLH-1 Locator consists of the following items.

- (1) Main unit ..... 1
- (2) Operation Manual (English) ..... 1
- (3) Soft Carrying Case ..... 1

### **Optional Accessory**

- (1) Marker (MK-1)

## 2. SYSTEM DESCRIPTION

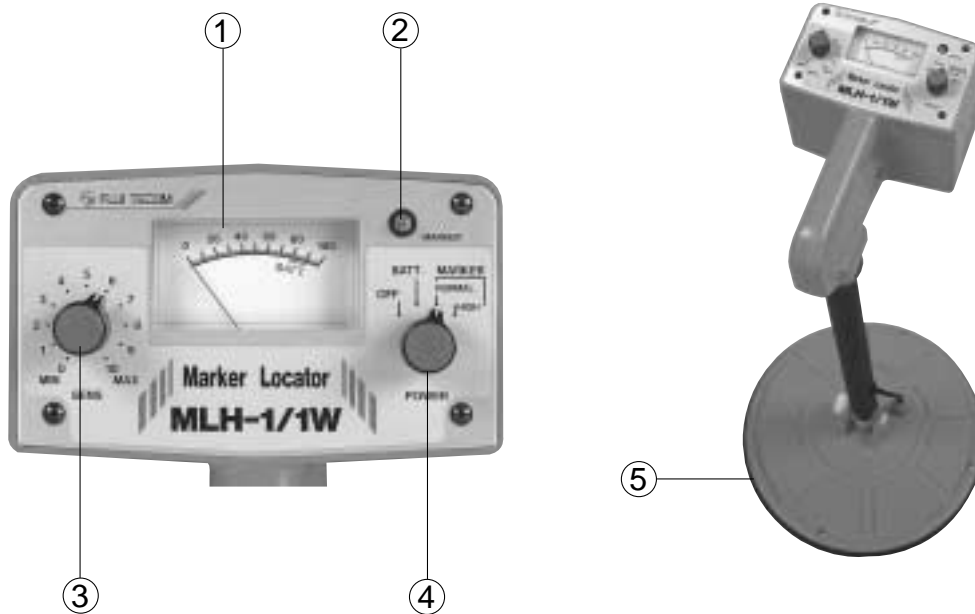

- ① Meter Indicator  
It indicates the residual battery power and the signal intensity from a marker.
- ② LED Indicator  
It turns on when the meter deflection exceeds 40.
- ③ Sensitivity Control  
Sensitivity level is increased or decreased by turning the knob.
- ④ Power and Mode Control  
To turn on and off the power, to check the residual battery power, or to choose the Low or High Mode.
  - OFF ..... To turn off the instrument
  - BATT..... To inspect residual battery power
  - MARKER-NORMAL ..... To locate a marker normally
  - MARKER-HIGH ..... To locate a marker which is buried at deeper depth
- ⑤ Antenna Disc

### 3. EXAMINATION BEFORE USE

When you operate MLH-1 Locator on site, check the residual battery power.

#### 3 – 1 BATTERY INSPECTION

MLH-1 Locator requires 8 pieces of UM-3 (1.5 Volts) Battery.

Turn the power switch Knob to “BATT.” and confirm if the needle of the meter moves to red zone of “BATT.” If the meter deflection does not reach the red zone, change the battery into the new ones right away.

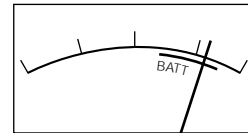

#### 3 – 2 BATTERY REPLACEMENT

Push the battery cover on the point ① and slide it down toward the direction of ② . Detach the battery cover and pull out the batteries (8 pieces).

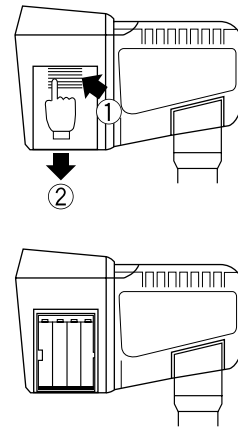

#### 3 – 3 OPERATING INSPECTION

Confirm if either “HIGH” mode or “NORMAL” mode works well by turning the switch Knob to “NORMAL” or “HIGH” position.

Turn the Switch Knob to “NORMAL” and also turn the sensitivity control knob to the middle of scales. Then confirm if the needle of the meter indicates good deflection and if the LED blinks by means of bringing the Antenna Face of the locator close to a marker.

Repeat the same operation with “HIGH” mode.

## 4. USAGE

### 4 – 1 HOW TO OPERATE MLH-1 LOCATOR

Turn on the power switch to “NORMAL” mode and also turn the sensitivity control knob to the middle of scales.

Move the antenna disc of the locator toward the directions of right and left parallel to ground surface. (Keeping space of five centimeters between the antenna and the ground surface is best position.)

When the meter deflection exceeds the full scales, turn the sensitivity control knob counter-clockwise and reduce its sensitivity.

#### CAUTION :

Do not have spare markers in your pocket or hand when operating MLH-1 Locator. It might cause misleading indication of the marker's position.

### 4 – 2 HOW TO OBTAIN THE POINT RIGHT UPON THE MARKER

- 1) Move the MLH-1 Locator toward the directions of right and left. Watch the meter deflection and obtain the point on the ground where the meter indicates the maximum deflection.
- 2) After having obtained the above point, move the MLH-1 Locator back and forth. You will obtain again the point of the maximum meter deflection right upon the marker.
- 3) The point crossed at the above two methods is the place right upon the buried marker under the ground.

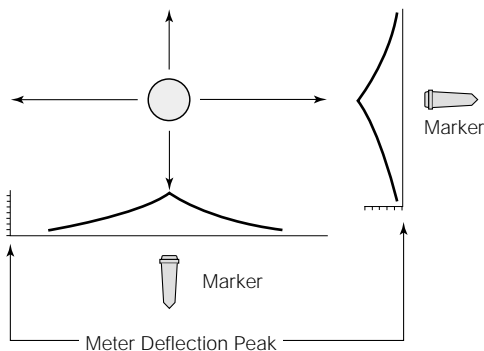

#### CAUTION :

When the meter deflection exceeds the maximum meter scales, reduce the sensitivity by turning the sensitivity control knob counter-clockwise. Then try it again.

#### CAUTION :

MLH-1 Locator is apt to be affected by the external magnetic field. When operating the MLH-1 Locator on site, confirm if there is a source of generating magnetic field such as power cable, power station or etc. near the site.

## 5. HOW TO LAY MARKER

When marker is laid under the ground, make a small hole as shown by the below figure and insert it into the hole.

**CAUTION :**

When the marker inserts in the hole, confirm if the marker will react well to MLH-1 Locator. After the confirmation, bury the marker.

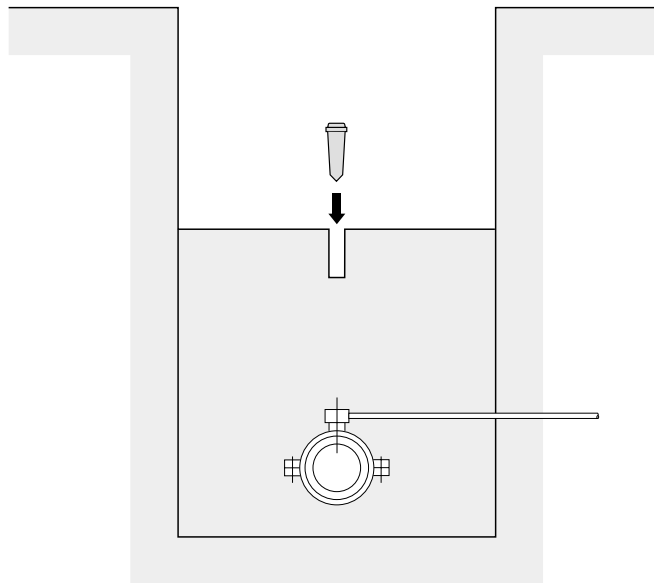

## 6. CAUTIONS FOR MARKER

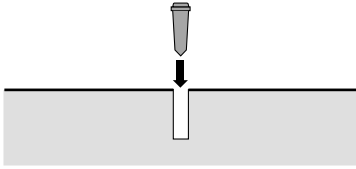

- ① Make a hole before laying the marker under the ground.

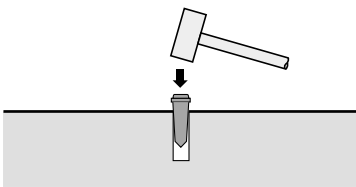

- ② When you hammer the marker, use a wooden hammer or rubber hammer with soft strike.

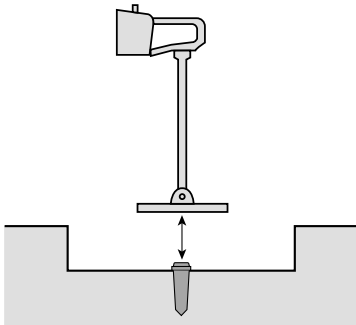

- ③ When laying the marker under the soil, confirm if the marker reacts well to MLH-1 Locator or not.

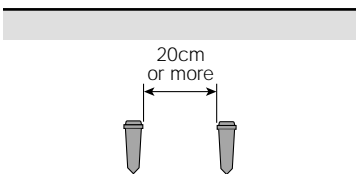

- ④ Keep the minimum interval between two markers more than 20cm.

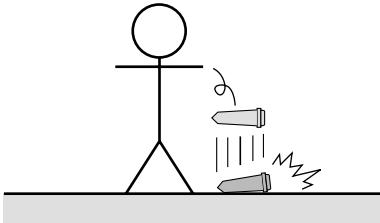

⑤ Do not drop the marker on the ground.

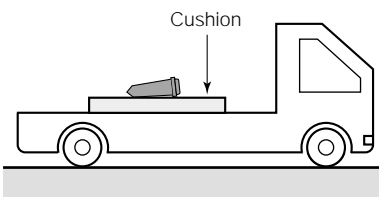

⑥ When transporting the marker, do not give it physical shock or vibration. Use a cushion or something which can minimize shock or vibration during its transportation.

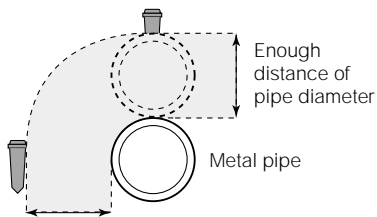

⑦ Take the space more than the diameter of metallic pipe as shown by the left figure.

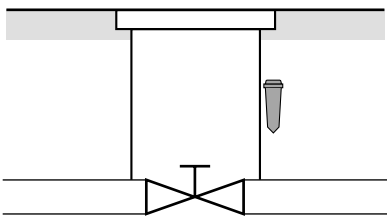

⑧ Do not lay the marker very close to metallic material as shown in the left figure.

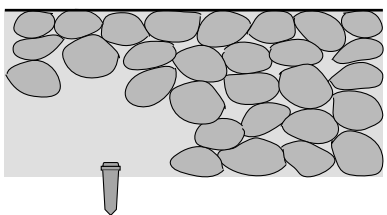

⑨ Do not cover the marker with the melted asphalt or a hot material.

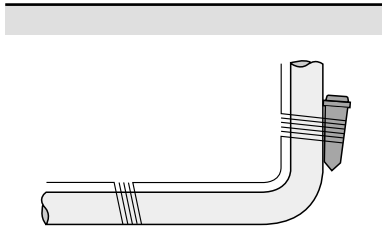

⑩ Do not place the marker by use of a wire or a Locating-Wire to a non-metallic pipe.

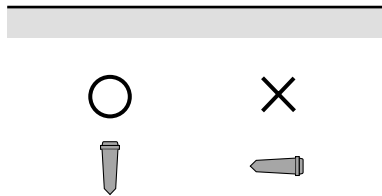

⑪ Do not lay the marker on its side when burying it under the ground.

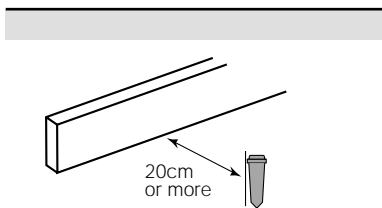

⑫ Keep the distance of 20cm or more between the marker and metallic material.

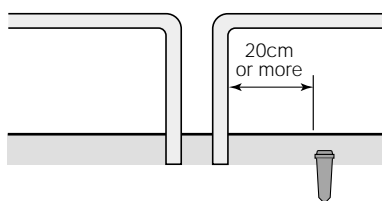

⑬ Take the space more than 20cm to the guardrail as shown by the left figure.

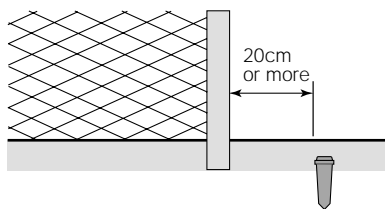

- ⑭ Take the space more than 20cm or more to the prop of fence as shown by the left figure.

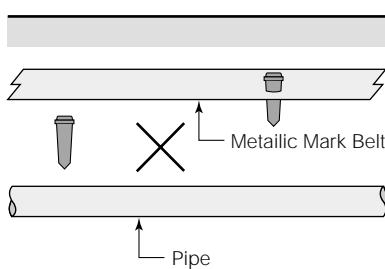

- ⑮ Do not use the marker together with the metallic mark belt as shown by the left figure.

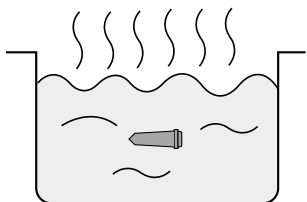

- ⑯ Do not put the marker in boiled water.

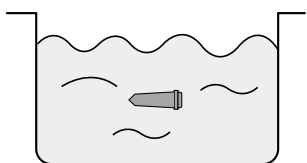

- ⑰ Do not put the marker in organic solvents such as thinner, toluene and so forth.

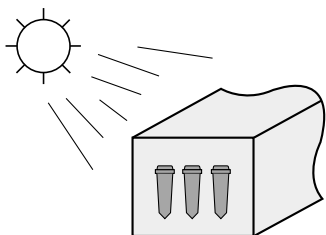

- ⑱ When preserving the marker for a long time, avoid the direct rays of the Sun.

## 7. APPLICATION EXAMPLES

Use the marker locating system to pinpoint the exact and precise points such as junction of branch pipe, dead-end of pipeline, joint of pipeline, standing-up of pipeline, repair point of pipeline, and so forth. This instrument in combination with the buried marker can be used for a key facility's identification.

The some of the application examples are given as follows:

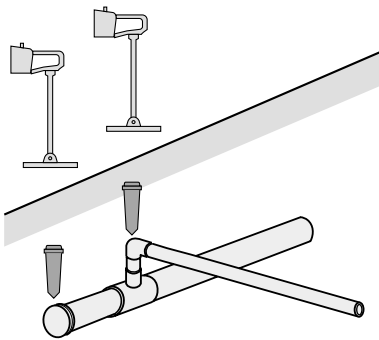

① Point of junction

The junction of branch pipe from the main pipe is an important point in the distribution network. The marker should be placed right upon the connected part of branch pipe to the main pipe.

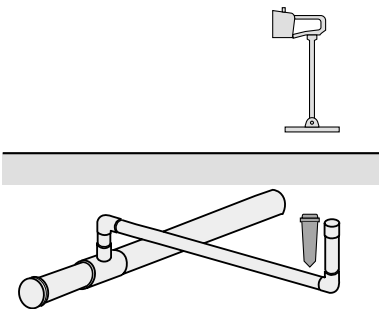

② Standing-up of pipeline.

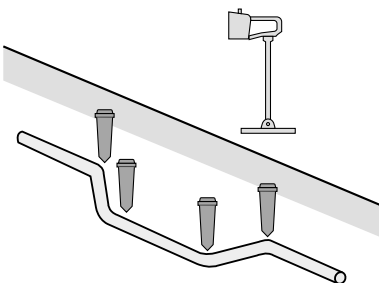

③ Bended-part of pipeline

The marker can show the bended-part of pipeline as shown by the left figure.

## 8. SPECIFICATION

- Frequency : Separate frequency for each utility type i.e.: Water, Gas, Waste Water, and Telecommunication
- Antenna : Air-core loop antenna
- Display : Meter deflection  
Speaker sound  
LED
- Power : 12 Volts DC (UM-3 x 8 pieces)
- Power consumption : 200mA with no signal
- Battery life : Approx. 7 hours with continuous operation  
(Alkaline Battery)
- Maximum locatable depth : Approx. 1.8m
- Dimensions : Amplifier : 149mm x 120mm x 223mm  
Antenna :  $\phi$ 273mm x 30mm  
Length : 700mm  
Weight : 1.9kg

## INSPECTION CERTIFICATE

MODEL: **MLH-1**      DATE: \_\_\_\_\_

SERIAL No: \_\_\_\_\_

We hereby certify that the undersigner checked the above instrument with careful attention under the Fuji interoffice inspection standard consisting of four main items as follows:-

(1) EXTERNAL APPEARANCE .....

(2) MECHANICAL WORK .....

\* Knob, lever & key   \* Connector   \* Joint

(3) ELECTRIC FUNCTION .....

\* Indicator & Display   \* Output   \* Sensitivity

\* Frequency               \* Input   \* Power

(4) OPERATION ON TEST SITE .....

\* Distance               \* Location               \* Level

\* Depth                 \* Flow

\* Direction             \* Pressure

\_\_\_\_\_  
Inspected by:



Instruments for the location of underground utilities and water leaks.

**FUJI TECOM INC.**

Head office : 1-3-1, Kanda Izumi-cho, Chiyoda-ku, Tokyo 101-0024, Japan

TEL : +81-3-3862-3196    FAX : +81-3-3866-1979

Web Site : <http://www.fujitecom.co.jp/>

E-Mail : [kaigai@fujitecom.co.jp](mailto:kaigai@fujitecom.co.jp)

Branch office : Sapporo, Sendai, Tokyo, Shinetsu, Nagoya, Osaka

Hiroshima, Kyushu

Technical development & training center : Niiza