

# FUJI NON-METALLIC PIPE LOCATOR

## NPL-100

### INSTRUCTION MANUAL



Instruments for the location of underground utilities and water leaks.

**FUJI TECOM INC.**

## Precautions



---

Before using this unit, completely read and comprehend the safety notes listed below.

- Follow the instructions and procedures described in this manual to operate this instrument.
- Always observe the precautions indicated on this instrument and manual.
- This is the product which meant Professional use. In use of this equipment, since a radio license may be needed, please use it in accordance with the radio regulation of your country.

### <Symbols>

The following symbols are used in this manual for the purpose of warning so that you can avoid property and personal damages.

 <b>WARNING</b>	This symbol indicates the existence of a potential danger that may cause death or serious injury.
 <b>CAUTION</b>	This symbol indicates the existence of a potential danger that may cause slight or moderate injury.
<b>CAUTION</b>	This symbol indicates the existence of a potential danger that may cause serious damage of NPL-100 or surrounding properties.

 <b>WARNING</b>
<ul style="list-style-type: none"><li>● While using this unit with a headphone set during the operation of this unit, be completely careful since it will be difficult to hear the background sounds.</li><li>● Do not replace the batteries and/or operate this unit with wet hands.</li><li>● When the batteries have been mounted to the battery box, handle this unit with great care. If the terminals are short-circuited, heat generation, bursting, fire, and/or injury will occur.</li><li>● When inserting the batteries into the battery case, pay attention to the polarity. Incorrect polarity will result in leakage, heat generation, damage, and other troubles.</li><li>● Do not put the batteries into the fire. Otherwise, you will suffer from bursting, fire, and/or injury.</li><li>● Do not disassemble the batteries. Otherwise, you will suffer from bursting, fire, and/or injury.</li></ul>



## CAUTION

- Do not hold the handle to swing the detector.
- Mount the battery cover certainly. Otherwise, the battery box may come off.
- Do not give a strong shock to the unit especially to the sensor (pick-up).
- Before removing the Vibrator from the fire hydrant, take out air inside the Vibrator by releasing the air vent cock.

## CAUTION

- Do not leave or install this unit in a hot place. Otherwise, the detector may fail.
- Use this unit only for the pipeline detection.
- This detector is not a complete waterproof model.
- Avoid immersion into water or operation in the rain.
- Do not drop the detector nor apply strong impact to it.
- Do not disassemble the detector.
- Do not touch the panel display strongly. Otherwise, the detector may fail.
- When the detector will not be used for a long period, remove the batteries.
- After finishing the operation, keep dry the inside of the Vibrator for storage.
- Do not bend the antenna by applying unreasonable force.
- Do not pull the pick-up cable unreasonably. Otherwise, the cable may be broken to dysfunction the pick-up.
- Always be aware of the ambient conditions.
- When disposing this detector, follow your local rules and regulations.

## **Warranty**

---

Fuji NPL-100 Non-metallic Pipe Locator is warranted for repair and replacement at free of charge within the period of twelve (12) months after the purchase from Fuji Representative or Distributor subject to the malfunction caused by the ordinary use in accordance with the instruction and caution given in this Instruction Manual.

---

1. OUTLINE .....	5
2. STRUCTURE .....	6
3. OPERATION PRINCIPLE .....	7
4. NAME AND FUNCTION OF EACH OPERATIONAL PART .....	8
4-1 Transmitter unit .....	8
4-2 Receiver unit .....	10
5. PREPARATION FOR OPERATING .....	13
5-1 Confirmation of each unit .....	13
5-2 Preliminary preparation .....	13
6. HOW TO OPERATE .....	14
6-1 How to set up each unit .....	14
6-2 How to check each action .....	14
6-3 How to change the battery .....	15
6-4 Operation method .....	16
7. METHODS FOR LOCATING .....	20
7-1 In case of locating only the distribution pipe .....	20
7-2 In case of locating the branch pipe through the distribution pipe .....	21
7-3 Method for locating the distribution pipe through the branch pipe .....	22
8. HOW TO STORE .....	23
8-1 Storage method .....	23
8-2 Storage after operation .....	23
9. SPECIFICATIONS .....	24

# 1. OUTLINE

The new NPL-100 non-metallic pipe locator is a further developed version of the PL-130 well-reputed in the water supply industry. The NPL-100 can detect the location, direction and bending of all kind of buried pipes on the ground surface by utilizing the principle that sound wave signal efficiently propagate inside water.

The sound wave signal is transmitted into the pressured water inside the buried pipes from the fire hydrant or the water meter by operating the oscillator and vibrator of the NPL-100, and the sensor of the NPL-100 catches the sound wave signal on the ground surface.

The NPL-100 can locate the following pipes.

- Polyvinyl chloride pipe
- Asbestos cement pipe
- Polyethylene pipe
- Ductile cast iron pipe
- Cast iron pipe
- Iron pipe
- Stainless steel pipe
- Copper pipe
- Lead pipe

The new features are as follows.

- The automatic adjustment function has reduced troublesome tuning work and has improved the performance of the locator.
- The transmission efficiency has been improved by lowering the resonance point of the vibrator.
- The hammer unit of optional accessories has improved the performance of the locator for locating branch pipes.
- The power supply module of optional accessories helps the operator on the site where a car battery is not available.

## 2. STRUCTURE

The NPL-100 locator is consisting of the transmitter unit and the receiver unit.

### ■ Transmitter unit

- **Oscillator**  
generates a tuned frequency controlled by the receiver unit.
- **Vibrator**  
transmits the sound wave signal into the buried water pipe from a fire hydrant or water meter.
- **Adaptor**  
attaches the vibrator to a water meter.
- **5-meter-long vibrator cable**  
used for connecting the oscillator and vibrator.
- **7-meter-long power supply cable**  
used for connecting the oscillator to the cigarette lighter socket of a car in order to utilize the power source of 12V DC.
- **Pipe holder**  
used for attaching the adaptor on the branch pipe.

### ■ Receiver unit

- **Sensor (Pick-up) with hand-switch**  
catches the sound wave signal on the ground surface.
- **Amplifier**  
amplifies the sound wave signal to operate the large indicator meter for reading and to enable the operator to listen to the sound wave signal.
- **Headphones**  
enables the operator to listen to the maximum sound wave signal.

### 3. OPERATION PRINCIPLE

#### ■ Transmitter unit

By means of attaching the vibrator to the fire hydrant or the water meter, the low frequency sound wave signal is transmitted into the pressured water inside of the buried pipe.

#### ■ Receiver unit

The Sensor (Pick-up) catches the sound wave signal which has reached the ground surface from the buried pipe and the amplifier operates the large indicator meter for reading the maximum numerical value and the headphones for listening to the maximum sound wave signal.

- The buried pipe has its own resonance frequency caused by its material and size. Therefore, in order to transmit the sound wave signal over a long distance, the sound wave signal is required to be tuned in the resonance frequency of each pipe.

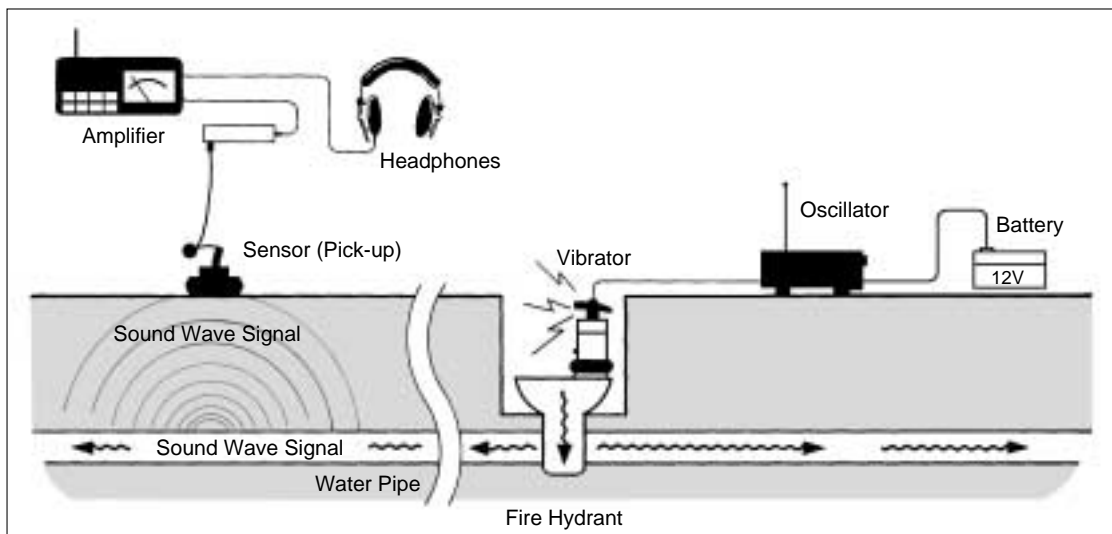

## 4. NAME AND FUNCTION OF EACH OPERATIONAL PART

### 4-1 Transmitter unit

#### 4-1-1 Oscillator

- ① Antenna connector  
connected to the telescopic receiving antenna.

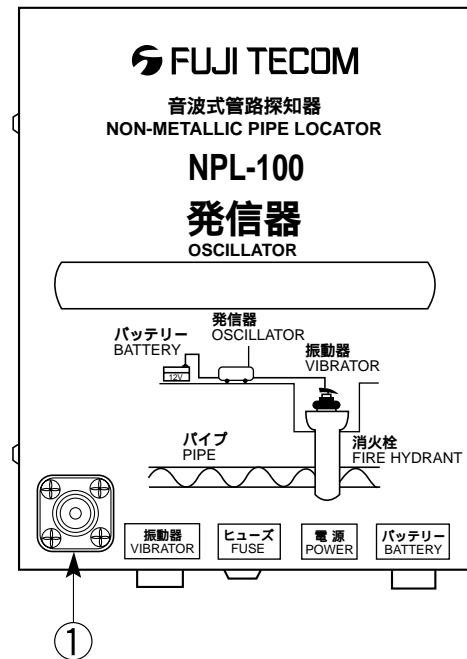

#### CAUTION

- Be careful that the heat sink of backside of the oscillator might be high temperature depending on using conditions.

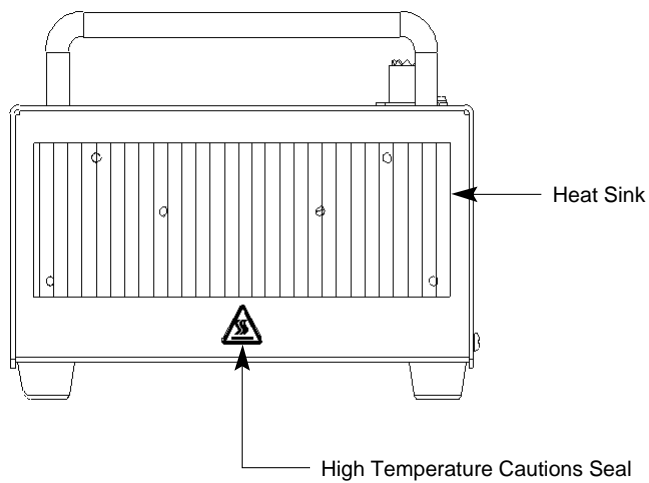

## 4. NAME AND FUNCTION OF EACH OPERATIONAL PART



### CAUTION

- Fuse: IEC standardized fuse.  
250V/5A
- Since the vibrator has weight, if it is carried by wet hand, it is very slippery and is dangerous.  
Be careful when you handle the vibrator.
- This oscillator is designed to work a mute function automatically to prevent from excessive use of battery as it uses a car battery to supply a power.

- ② Output jack  
used for connecting to the vibrator with the 5-meter-long vibrator cable.
- ③ Fuse box  
will break at 5A or more.
- ④ Power switch (O : OFF I : ON)  
used for operating the transmitter unit.
- ⑤ Power jack  
used for connecting to the 7-meter-long power supply cable.

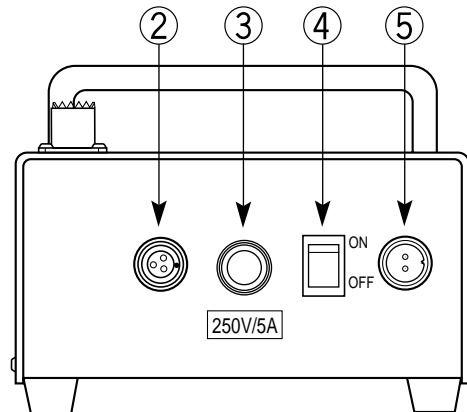

### 4-1-2 Vibrator

- ⑥ Connector Output jack  
used for connecting to the oscillator with the 5-meter-long vibrator cable.
- ⑦ Handle  
used when attaching to and removing from the fire hydrant.
- ⑧ Air bleeding knob  
used for taking out the air bubble inside of the vibrator.
- ⑨ Fuji coupler  
meets all of the outlet of the domestic fire hydrants.

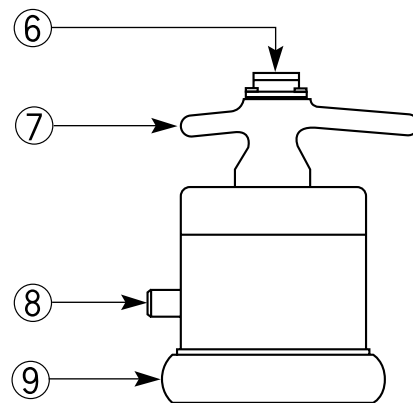

## 4. NAME AND FUNCTION OF EACH OPERATIONAL PART

### 4-1-3 Adaptor

- ⑩ Screw head  
jointed at the center of the speaker of the vibrator.
- ⑪ Handle  
push down the disk on the face of the water meter.
- ⑫ Disk  
fixed on the face of the water meter for transmitting the sound wave signal into the water pipe.
- ⑬ Clamp  
clamps the flange of the water meter.

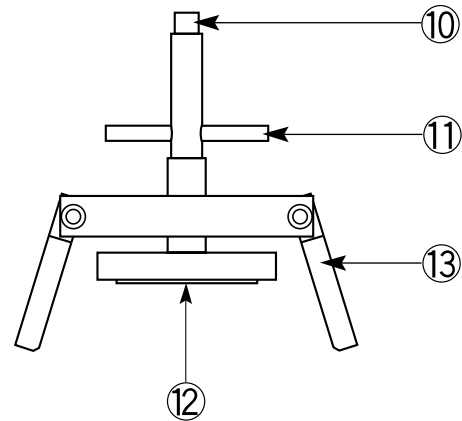

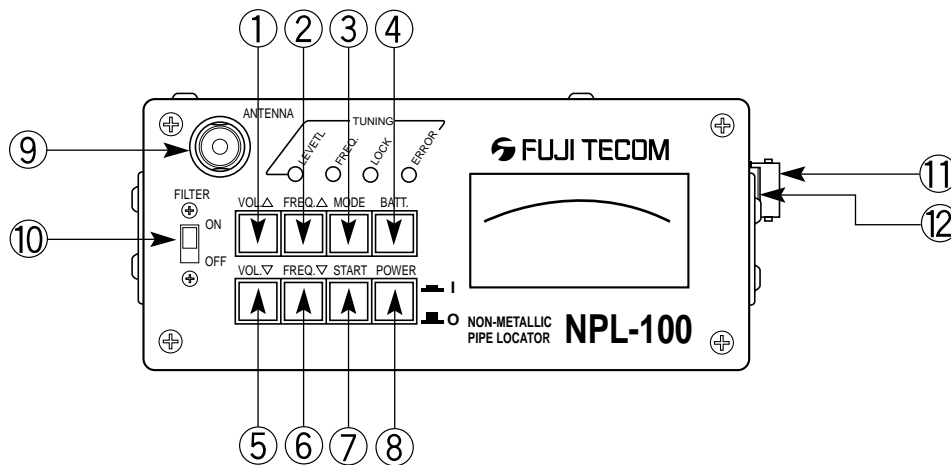

### 4-2 Receiver unit

#### 4-2-1 Amplifier



- ① Volume UP key  
used for controlling the meter needle and turning up the volume in the headphones.
- ② Frequency UP key  
used for tuning in the resonance frequency of the higher frequency.
- ③ Mode key  
used for changing over between the continuous sound signal mode and the intermittent sound signal mode.
- ④ Battery check key  
used for checking the battery power.
- ⑤ Volume DOWN key  
used for controlling the meter needle and turning down the volume in the headphones.
- ⑥ Frequency DOWN key  
used for tuning in the resonance frequency of the lower frequency.

## 4. NAME AND FUNCTION OF EACH OPERATIONAL PART

- |   |   |
|---|---|
| ⑦ Start key<br>used for commencing the automatic adjustment function.   | ⑩ Filter switch<br>used for tuning on and off the filter.               |
| ⑧ Power switch key (  : OFF  : ON )<br>used for turning on and off power. | ⑪ Sensor (Pick-up) jack<br>used for connecting to the sensor (Pick-up). |
| ⑨ Antenna connector<br>used for connecting to the transmitting antenna.   | ⑫ Headphone jack<br>used for connecting to the headphones.              |

### Motion of LED

#### ● LEVEL

The receiving level under frequency automatic adjustment is adjusted automatically. It blinks during frequency automatic adjustment.

#### ● FREQ

The frequency under frequency automatic adjustment is adjusted automatically. It blinks during frequency automatic adjustment. In case the frequency button is pushed with a manual adjustment. LED lights up.

#### ● LOCK

When automatic adjustment of the resonance frequency passed to a pipeline is completed, LED lights up.

#### ● ERROR

When it is recognized that automatic adjustment cannot be taken during level adjustment or frequency adjustment, the error LED lights up. At this time, a level LED or frequency LED lights up simultaneously. If power supply voltage becomes less than 6.3V, LED will blink.

## 4. NAME AND FUNCTION OF EACH OPERATIONAL PART

### 4-2-2 Sensor (Pick-up) with hand-switch

① Sensor (Pick-up)

The acceleration sensor.

② Mute switch button

used for avoiding the displeased noise listened in the headphones.

③ Grip assembly

used for operating the pick-up on the ground surface.

④ Plug

inserted into the jack of the amplifier.

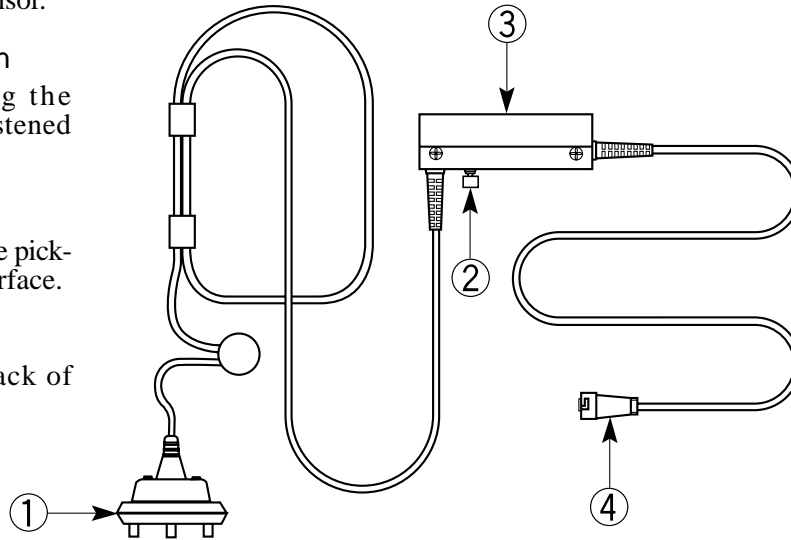

### 4-2-3 Headphones

The headphones are connected to the amplifier with its specially designed plug which operates the power switch.

Therefore, without inserting into the jack of the amplifier, the amplifier does not work and prevents the consumption of battery power.

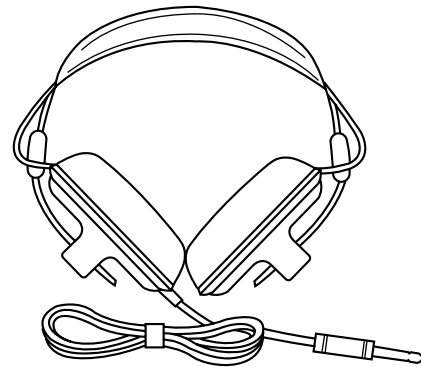

## 5. PREPARATION FOR OPERATING

### 5-1 Confirmation of each unit

- (1) Check if all the units are ready.
- (2) When using the fire hydrant, the operator is required to prepare in advance the apparatus for operating the valve and cap of the fire hydrant.
- (3) A piece of chalk or something is required to mark on the ground surface.

### 5-2 Preliminary preparation

- (1) Check the location of fire hydrant or water meter.
- (2) When using the fire hydrant, clean the outlet of the fire hydrant in advance.
- (3) In case that the fire hydrant is not located on the site or useless, use the water meter after cleaning the meter face.

## 6. HOW TO OPERATE

### 6-1 How to set up each unit

- (1) Connect the telescopic receiving antenna to the antenna connector of the oscillator.  
Connect the transmitting antenna to the antenna connector of the amplifier.
- (2) Connect the vibrator to the oscillator with the 5-meter-long vibrator cable and then connect the oscillator to the cigarette lighter socket of a car with the 8-meter-long power supply cable.
- (3) Connect the plug of the hand-switch to the sensor jack of the amplifier and insert the headphone plug into the headphone jack of the amplifier.

### 6-2 How to check each action

- (1) Switch on the transmitter unit and receiver unit.
- (2) Confirm that the LED on the receiver unit lights up.
- (3) Press the Battery check key of the amplifier to confirm that the meter needle is located within the red line or on the right-hand side of the red line.
- (4) Press the Start key of the amplifier to check if the vibrator works.
- (5) Press the mute switch button of the hand-switch to check if the meter needle and the headphones work properly.
- (6) If each part operates properly, switch off the transmitter unit and receiver unit.  
And then jump to "Operation method".

## 6. HOW TO OPERATE

### 6-3 How to change the battery

- (1) This unit uses Alkaline Dry Battery (LR6) × 6 (9V)
- (2) Remove the battery cover and replace the old batteries with new ones.
- (3) After reinsertion of new batteries, be sure to remount the battery cover firmly.

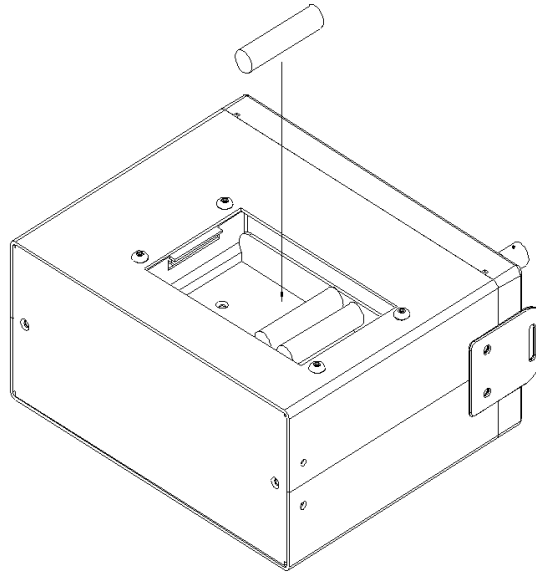

#### **WARNING**

When replacing batteries, pay attention to the polarity. Incorrect polarity of batteries will cause burst, fire and injuries.

Do not use different kinds of batteries at the same time. This will result in burst and leakage.

When disposing batteries, follow your local rules and regulations.

#### **CAUTION**

We do not assure this unit when it damages by using other batteries that are not specified by us.

An error of continuous operating time will occur due to the difference in battery capacity in case using other batteries that are not specified by us.

## 6. HOW TO OPERATE

---

### 6-4 Operation method

#### 6-4-1 In case of using the fire hydrant

- (1) Bring the whole of NPL-100 locator near by the fire hydrant.
- (2) Attach the vibrator to the outlet of the fire hydrant, then slowly open the valve.
- (3) Loosen the air-bleeding knob to take out the air bubbles inside of the vibrator.
- (4) After confirming the power switch of the oscillator has been set at OFF position, connect the power supply cable to the power jack of the oscillator.
- (5) Insert the plug of the power supply cable into the cigarette lighter socket of a car in order to utilize the power source of 12V DC.
- (6) Connect the 5-meter-long vibrator cable to the output jack of the oscillator.
- (7) Connect the telescopic antenna to the antenna connector of the oscillator.
- (8) Jump to 6-4-3.

#### 6-4-2 In case of using the water meter

- (1) Bring the whole of NPL-100 near by the water meter.
- (2) Attach the adaptor to the water meter.  
\*Firmly fix the adaptor by rotating its handle to the face of the water meter.
- (3) Attach the vibrator to the adaptor with its screw head.  
\*When attaching the vibrator to the adaptor, firmly fix the female screw located in the center of the speaker of vibrator to the screw head of the adaptor.
- (4) After confirming the power switch of the oscillator has been set at OFF position, connect the power supply cable to the power jack of the oscillator.
- (5) Insert the plug of the power supply cable into the cigarette lighter socket of a car in order to utilize the power source of 12V DC.
- (6) Connect the 5-meter-long vibrator cable to the output jack of the oscillator.
- (7) Connect the telescopic receiving antenna to the antenna connector of the oscillator.
- (8) Jump to 6-4-3.

## 6. HOW TO OPERATE

---

### 6-4-3 How to tune in a resonance frequency

- (1) Switch on the transmitter unit and then switch on the receiver unit.
- (2) Confirm that the LED on the receiver unit lights up.  
The operator should stand with wearing the receiver unit at the distance about 5 to 10 meters away from the vibrator on the fire hydrant.
- (3) Put the sensor (pick-up) on a position supposed to be right upon the buried pipe and then press the Start key.  
The vibrator starts working, and the automatic adjustment LED on the amplifier moves from the LEVEL position to the LOCK position through the FREQUENCY position. The automatic adjustment has been completed when the LED is on the LOCK position.  
\* Do not move the sensor (pick-up) during the automatic adjustment LED is blinking.  
\* In case that the LED is blinking on the ERROR position, repeat the automatic adjustment after moving the sensor (pick-up) to another position.  
  
For better locating work, manipulate the operation keys : Volume UP key, Volume DOWN key, Frequency UP key, Frequency DOWN key, and Mode key.
- (4) Mark on the ground surface where the meter needle shows a maximum and a maximum level of sound wave signal can be listened.

## 6. HOW TO OPERATE

### 6-4-4 In case of using the water meter together with the optional hammer unit

The hammer unit has been developed especially for locating branch pipes. The hammer unit makes it possible to produce a stronger striking noise by attaching it between the standard adaptor and vibrator. The striking noise is transmitted inside the pipes.

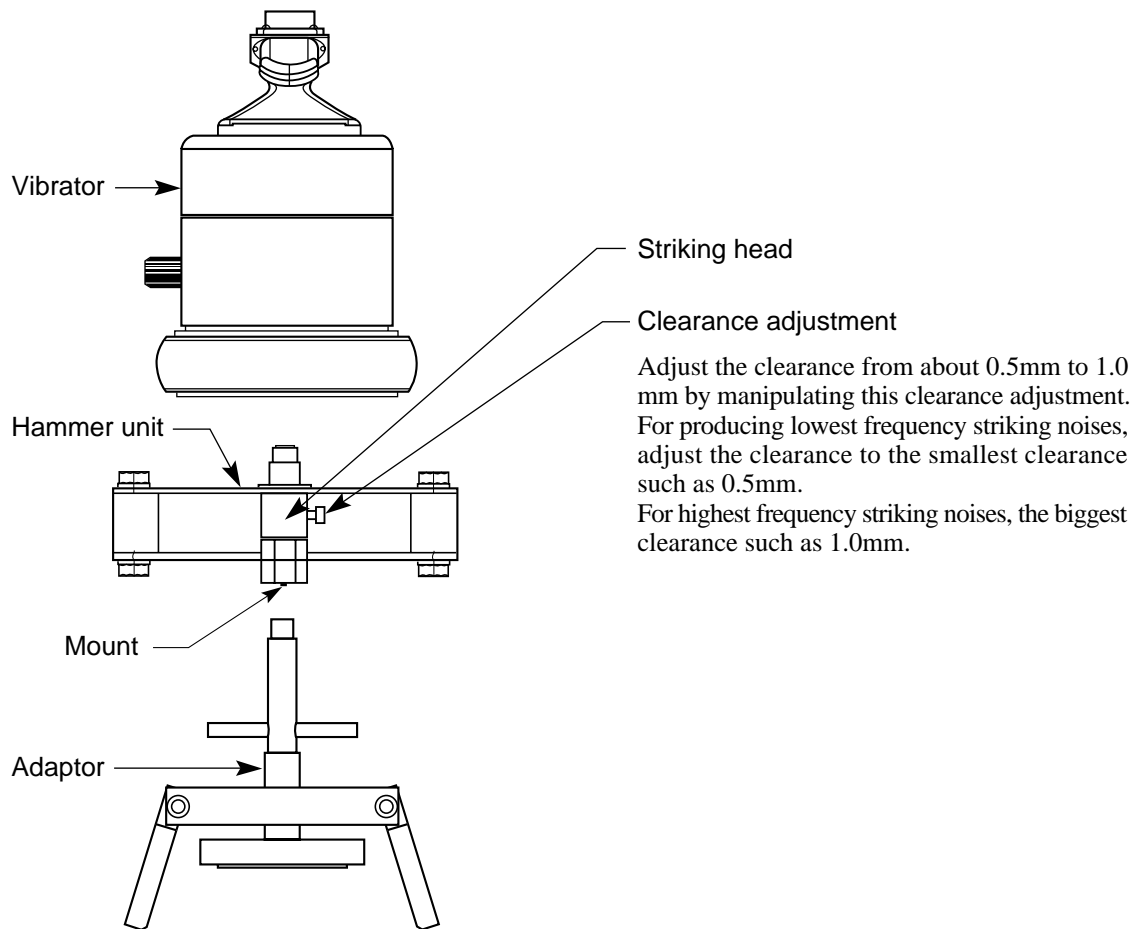

- (1) Attach the adaptor to the water meter.  
\* Firmly fix the adaptor to the face of the water meter.
- (2) Attach the hammer unit to the adaptor and then attach the vibrator to the hammer unit with its screw head.
- (3) After confirming the power switch of the oscillator has been set at OFF position, connect the power supply cable to the power jack of the oscillator.
- (4) Insert the plug of the power supply cable into the cigarette lighter socket of a car in order to utilize the power source of 12V DC.

## 6. HOW TO OPERATE

---

- (5) Connect the 5-meter-long vibrator cable to the output jack of the oscillator.
- (6) Connect the telescopic receiving antenna to the antenna connector of the oscillator.
- (7) Switch on the transmitter unit and then switch on the receiver unit.  
Confirm that the LED on the receiver unit lights up.  
The operator should stand with wearing the receiver unit at the distance about 5 to 10 meters away from the vibrator.
- (8) Put the sensor (pick-up) on a position supposed to be right upon the buried pipe and then press the Start key.  
The vibrator starts working, and the automatic adjustment LED on the amplifier moves from the LEVEL position to the LOCK position through the FREQUENCY position.  
The automatic adjustment has been completed when the LED is on the LOCK position.
  - \* Do not move the sensor (pick-up) during the automatic adjustment LED is blinking.
  - \* In case that the LED is blinking on the ERROR position, repeat the automatic adjustment after moving the sensor (pick-up) to another position.For better locating work, manipulate the operation keys : Volume UP key, Volume DOWN key, Frequency UP key, Frequency DOWN key, and Mode key.
- (9) Mark on the ground surface where the meter needle shows maximum and a maximum level of sound wave signal can be listened.

**Note :** There is a case that it is easy to listen to the sound wave signal if the Filter switch of the amplifier is set to the OFF position when using the optional hammer unit.  
Because striking noise includes much high frequency noises.  
In case that the Filter switch is set to the ON position, the filter cuts the noises of 30Hz lower or higher than the set frequency band of the output.  
When the Filter switch is set to the OFF position, the noises generating between 80Hz and 500Hz can be listened.

## 7. METHODS FOR LOCATING

### 7-1 In case of locating only the distribution pipe

(1) Adjustment

Adjust with all of the operational parts for commencing the survey.

(2) Detection of a maximum point

In the first stage of the survey, cross the street from side to side looking for the point of the maximum sound wave signal as shown in the Fig.-1.

(3) Decision of a location

When detected the maximum point on the ground surface, draw a mark there with the chalk.

Go along the street detecting maximum points and draw marks at the maximum points as shown in the Fig.-2.

(4) Re-tuning

When the sensitivity is weakened on a point on the ground, tune again the sound wave signal in the resonance frequency of a pipe.

When the sensitivity is weakened, the operator should suppose the fact that a different kind or size of pipe has been jointed at the point under the ground as shown in the Fig.-3.

#### Example for locating only the distribution pipe

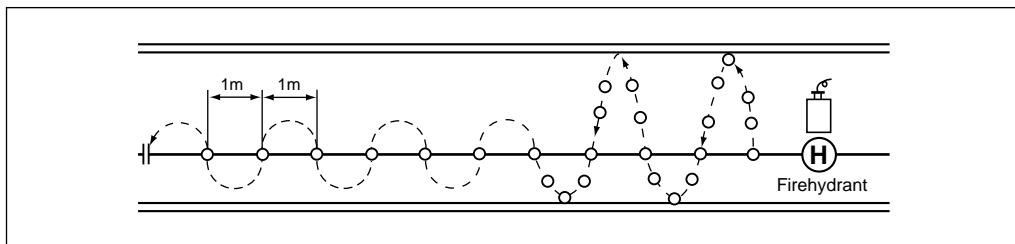

Fig.-1

#### Straight line decides the location of pipe

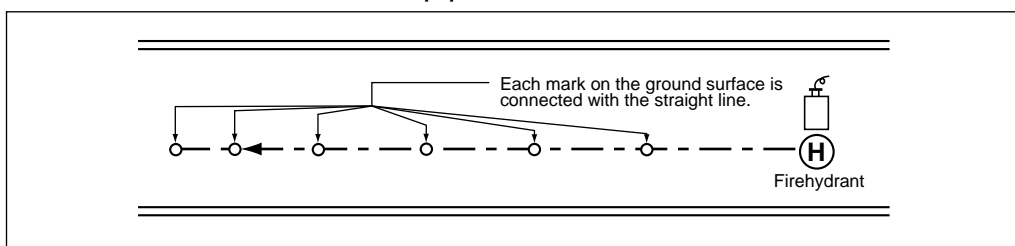

Fig.-2

#### Example for re-tuning

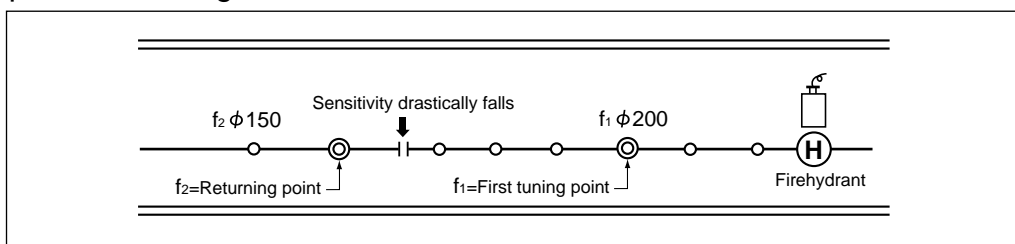

Fig.-3

## 7. METHODS FOR LOCATING

### 7-2 In case of locating the branch pipe through the distribution pipe

This is the method for locating the branch pipe by means of transmitting the sound wave signal from the fire hydrant fitted on the distribution pipe as shown in the Fig.-4.

(1) Adjustment

Adjust with all of the operational parts for commencing the survey.

(2) Tuning

At the place of (A) as shown by the Fig.-4, tune in the resonance frequency " $f_a$ " of the distribution pipe.

(3) Location of the distribution pipe

Detect the maximum point of the sound wave signal.

(4) Re-tuning

At the place of (B) as shown by the Fig.-4, tune again in the resonance frequency " $f_b$ " of the branch pipe.

(5) Location of the branch pipe

Detect the maximum point of the sound wave signal.

Example for locating the branch pipe through the distribution pipe

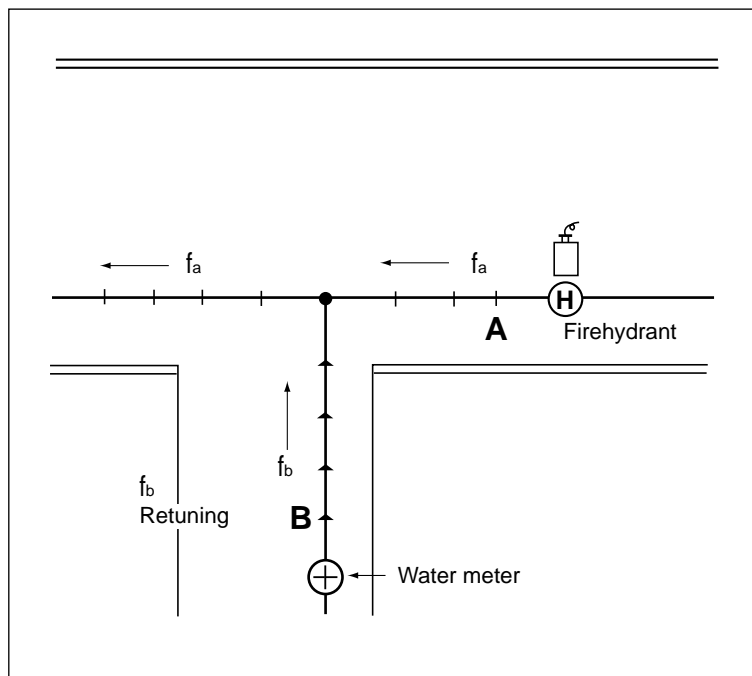

Fig.-4

## 7. METHODS FOR LOCATING

### 7-3 Method for locating the distribution pipe through the branch pipe

This is the method for locating the distribution pipe by means of transmitting the sound wave signal from the water meter fitted on the branch pipe as shown in the Fig.-5.

(1) Adjustment

Adjust with all of the operational parts for commencing the survey.

(2) Tuning

At the place of (A) as shown in the Fig.-5, tune in the resonance frequency " $f_a$ " of the branch pipe.

(3) Location of the branch pipe

Detect the maximum point of the sound wave signal.

(4) Re-tuning

At the place of (B) as shown in the Fig.-5, tune again in the resonance frequency " $f_c$ " of the distribution pipe.

(5) Location of the distribution pipe

Detect the maximum point of the sound wave signal.

Example for locating the distribution pipe through the branch pipe

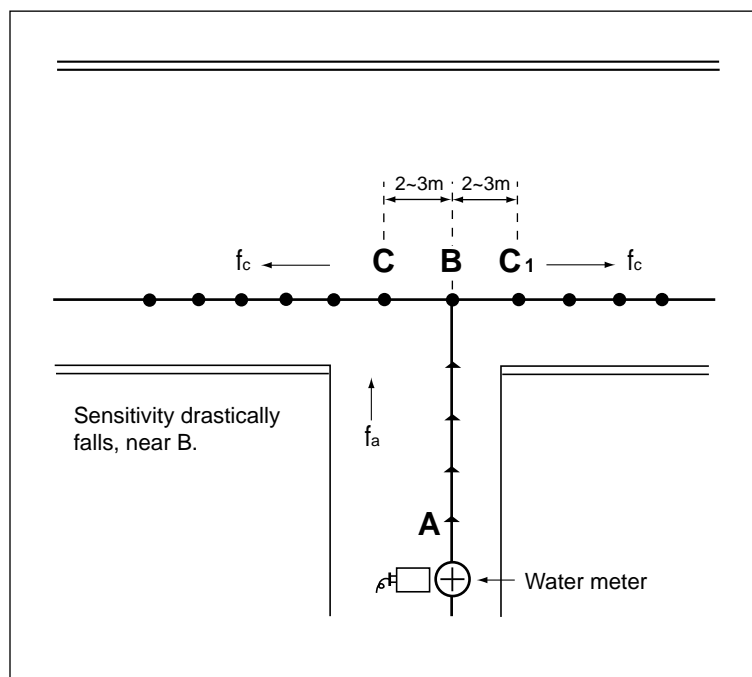

Fig.-5

## 8. HOW TO STORE

### 8-1 Storage method

When this unit will not be used for a long period, store it according to the following procedures.

- (1) Check any of the system components, including instruction manual, is not missing.
- (2) Remove the batteries. If the batteries are mounted in the unit for a long period, leakage may occur to damage the equipment.
- (3) Do not store the unit in a wet place.

### 8-2 Storage after operation

When storing the unit, observe the following precautions.

- (1) Clean each pickup sensor and vibrator to remove the mud and dirt completely and place them in the storage case, otherwise it may occur to stain other components and damage the equipment.
- (2) Place only this component unit in the storage case. Otherwise, it may be damaged or faulty.

## 9. SPECIFICATIONS

### ■ OSCILLATOR

Power Source	: 12V DC
Power Consumption	: 50W
Frequency	: 50~500Hz
Minimum Operation Voltage	: 10V
Operating Temperature Range	: -10 °C ~ +55 °C
Size	: 170 (W) × 210 (L) × 120 (D) mm
Weight	: 1.35kg

### ■ AMPLIFIER

Power Source	: LR6 Battery 1.5V × 6pcs. (9V DC)
Current Consumption	: 110mA
Amplification	: 120dB
Frequency	: 80~500Hz
Operating Temperature Range	: -10 °C ~ +55 °C
Headphone Output	: 8 Ω (Stereophonic Type)
Level Indication	: Meter Needle

#### <Radio communication system>

Transmission Frequency	: 458.8 MHz
Modulation	: Direct Frequency Modulation
Transmitting Power	: 60mW
Output Impedance	: 50ohm
Minimum Operation Voltage	: 6.3V
Duty Cycle Class *1	: 4 (16.7%, Maximum 1 Min. in 6 Min)
Size	: 170 (W) × 75 (L) × 140 (D) mm
Weight	: 1.25kg

### ■ SENSOR (PICK-UP)

Type	: Piezoelectric Acceleration Sensor
Sensitivity	: 0.7V/g (at 400Hz)
Size	: φ 80 × 50 mm
Weight	: 0.5kg

\*1 About Duty Cycle Class

In order to control operation of transmitter from a receiver, NPL-100 uses radio.

When automatic adjustment is performed once, the state is held fundamentally and detection is continued.

The time concerning one automatic adjustment is for about 30 seconds, and outputting radio is continued in the meantime.

Since the rate which performs automatic adjustment is assumed to be about 1 time in 3 minutes, the Duty Cycle Class is specified.

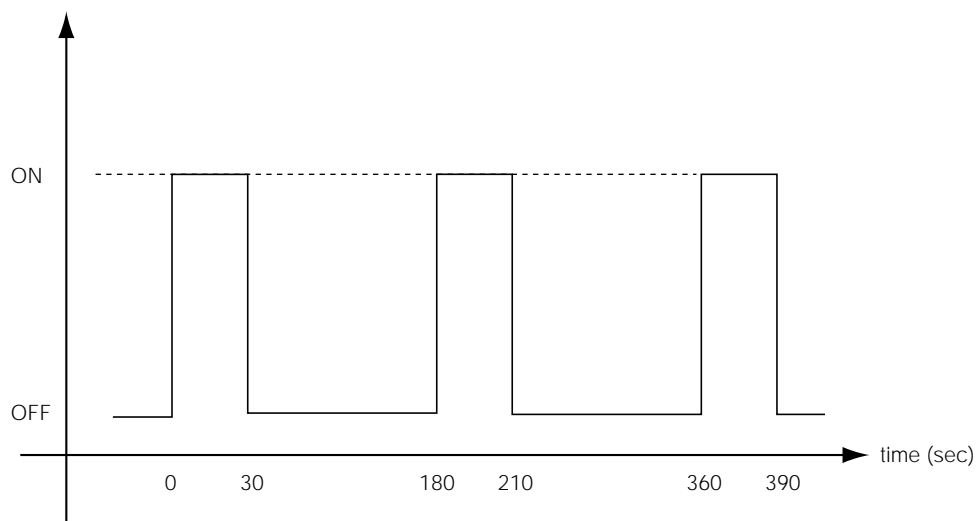

---

Inspected by:



Instruments for the location of underground utilities and water leaks.

**FUJI TECOM INC.**

**Head office** : 1-3-1, Kanda Izumi-cho, Chiyoda-ku, Tokyo 101-0024, Japan  
TEL : +81-3-3862-3196 FAX : +81-3-3866-1979  
Web Site : <http://www.fujitecom.co.jp/>  
E-Mail : [kaigai@fujitecom.co.jp](mailto:kaigai@fujitecom.co.jp)

**Branch office** : Sapporo, Sendai, Tokyo, Shinetsu, Nagoya, Osaka  
Hiroshima, Kyushu

**Technical development & training center** : Niiza